



















## List of acronyms and abbreviations

<b>Acronyms</b>	<b>Definition</b>
ACE	Advanced Certificate in Education.
ANA	Annual National Assessment
AS	Assessment Standards.
BL1	Question one from the interview schedule.
CAPS	Curriculum and Assessment Policy Statement
CASE	Cognitive Acceleration through Science
DBE	Department of Basic Education.
DoE	Department of Education

EA1	Educator from the resourced school.
EB2	Educator from the under-resourced.
FET	Further Education and Training Band.
G1	Group one.
GET	General Education and Training band
LA	Learner from the resourced school.
LA1	First learner from the resourced school.
LA1G1	First learner from the resource school in Group one.
LA3G5	Third learner from the resourced school in group 5.
LB	Learner from the under-resourced.school

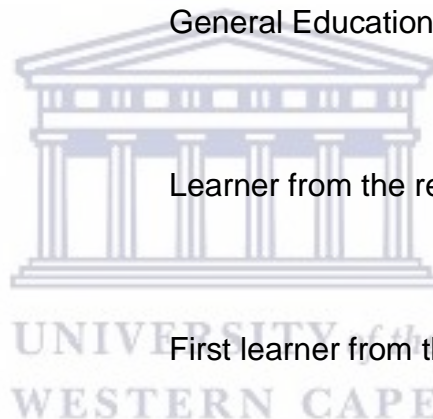

LB1	First learner from the under-resourced school.
LN1	Theme one from the observation schedule.
LO	Learning Outcomes.
NCS	National Curriculum Statement.
NSC	National Senior Certificate
NTA	National Teaching Award.
OECD	Organization for Economic Cooperation and Development
OBE	Outcomes Based Education.
RNCS	Revised National Curriculum Statement.

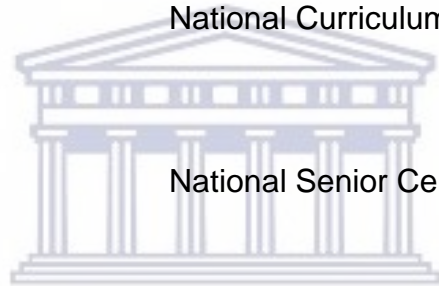

UNIVERSITY of the  
WESTERN CAPE

SA

Resourced school

SB

Under-resourced school

SMT

School Management Team.

TRINSET

Transkei in Service Training.

UWC

University of the Western Cape.



UNIVERSITY *of the*  
WESTERN CAPE

# CHAPTER 1

## INTRODUCTION TO THE STUDY

### 1.1 Introduction

The aim of the study is to compare the teaching and learning of Ohm's law in Physical Sciences in resourced and under-resourced schools. The research topic is a challenging section of the Physical Sciences curriculum. This chapter gives the background to the study and the context in which the study is conducted. The research problem and the research question are described. It also highlights the following: The state of Science education in South Africa, intervention in Science Education, the significance of the study, the limitations of the study and the structure of the thesis.

### 1.2 Background to the study.

The learners of all ages find difficulties in understanding Science concepts (Zacharia & Anderson, 2007). This lack of understanding affects the performance of learners especially, in Physical Sciences. The results in Physical Science in the National Senior Certificate (NSC) examinations in South Africa indicated that the subject is in serious difficulty due to the drastic drop in results of learners in the questions that need the application of the laws in Physics. There is a poor performance of learners in Physical Sciences nationally, provincially, and at district level down to school level.

The National Senior Certificate Examination National Diagnostic report highlighted that the learners' achievement in this learning area has been poor especially in the Eastern Cape Province, particularly in questions based on practical work (NDR, 2013). It is further indicated in the report that one of the topics which contributed to poor performance is electric circuits (Ohm's law and its application). As recently as 2016, the diagnostic report highlighted the poor performance of the learners in the electric circuit topic, recording the

pass rate in the electric circuit question as 34%. This report supported the earlier NCS chief markers report which highlighted that the question that involved the application of Ohm's law (Question 8 in the question paper ) was the question that was most poorly answered in the Eastern Cape Province (Department of Education, 2014).

The question by question analysis from the chief marker's report (figure 1) shows that question 8 was poorly answered. Figure 1 shows that the majority of the questions were poorly answered as the percentage pass of learners is below fifty percent. The graph indicated that the percentage pass in the topic which deals with electric circuit is fifty-one percent, which is low. The electric circuit question was the question that requires a learner's higher order thinking skills and the application of Ohm's law. These results indicate that the learners are struggling to answer this question. The graph also shows that the percentage pass for the learners in question two is 42%, question three is 67%, question four is 63%, question five is 42%, question six is 70 %, question seven is 43%, question eight is 5%, question nine is 60% and question ten is 41%

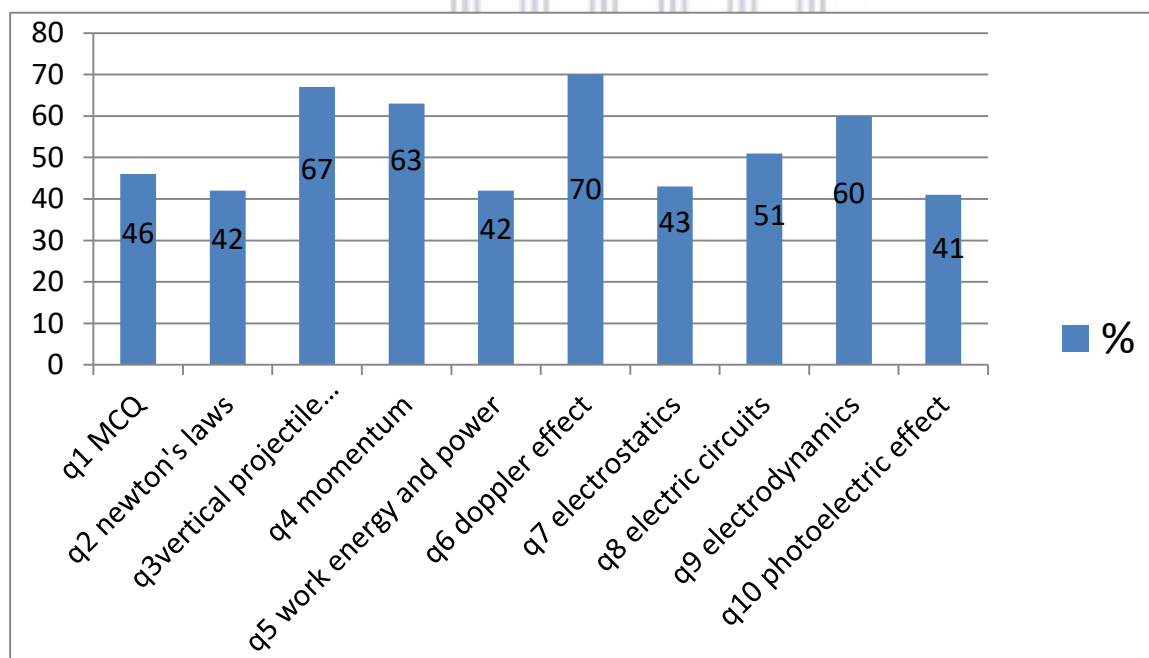

**Figure1: Question by question analysis for the 2014 Physical Science results.**

Table 1 reflects the results over the past seven years and is a summary of the state of Physical Sciences teaching and learning nationally, provincially, in the district and down

to school level. School A (resourced school) and school B (under-resourced school) are the schools where the research was undertaken and school C is the researcher's school.

**Table 1: Pass rates in Physical Science from 2010-2016.**

YEAR	NATIONALLY %	PROVINCIALY %	EDUCATION DISTRICT %	SCHOOL A	SCHOOL B	SCHOOL C
2010	47.8	43	44	79	23	95.2
2011	53.4	46	41.7	77	35	85.7
2012	61.3	50.4	44.7	63	31	74.6
2013	60	67	52.8	67	26	70.9
2014	61.5	51.5	46.3	72.5	13	74.6
2015	56.5	49.5	43	68	14	61
2016	62	49.6	42.8	70	21	68

Table 1 shows that at national level the pass percentage in 2010 was 47.8%, 2011 was 53.4, in 2012 was 61.3%, in 2013 was 60, 2014 was 61%, 56.5% in 2015 and 62% in 2016. Compared to the Eastern Cape Province, the results showed that the pass rate was mostly lower than the national pass rate (43% in 2010, 46% in 2011, 50.4% in 2012, 67% in 2013, 51.5% in 2014, 49.5% in 2015 and 49.6% in 2016). In the district where the researcher is teaching, the percentage pass rate dropped even lower (44% in 2010, 41.7% in 2011, 44.7% in 2012, 52.8% in 2013, 46.3 % in 2014, 43% in 2015 and 42.8% in 2016).

In the two schools where the research was conducted, there was a dramatic difference in the pass rate even though the schools were in close proximity. In one school, the resourced Dinaledi School a pass rate between 60 and 70 % was maintained. (79% in 2010, 77% in 2011, 63% in 2012, 67% in 2013, 72% in 2014, 68% in 2015, and 70% in 2016 for the resourced school referred to as School A in this study. For the under-resourced school (school B) the results were very low (23% in 2010, 35% in 2011, 31% in 2012, 26% in 2013, 13% in 2014, 14% in 2015 and 21% in 2016). In contrast, in the school (School C) where the researcher was teaches in the same area as the other two

the results were maintained at above 70% even though 2015 was an exception (95% in 2010, 85.7 % in 2011, 74.6% in 2012, 70, 9% in 2013, 74.6% in 2014, 61% in 2015 and 70% in 2016).

The table shows that in some schools the results are not good and have a negative impact on the overall performance throughout the country. Due to the discrepancies in the achievement of learners in this education district, the researcher decided to conduct the research in order to compare teaching and learning of Ohm's law in Physical Sciences in chosen resourced and under-resourced schools.

### **1.2.1 Context of the study**

The research was conducted in two schools situated in the same district. One school (school A) is a resourced Dinaledi school and other one is an under-resourced school (school B) which starts from grade 10 to grade 12. School A is a school which is thirty kilometers from town, well built, with seven hundred learners. The school has a library which is well resourced. There are twelve classes: five grade ten classes, four grade eleven classes and three grade twelve classes. There are three Physical Sciences classes in grade ten, three grade eleven classes and one grade twelve class. The number of grade ten learners is one hundred and fifty-four. Three hundred and fifty-four learners study Physical Sciences under the guidance of two Physical Sciences educators. The school employs twenty-five educators under the management of three heads of department, one deputy principal and one principal. There is a fully equipped laboratory and a computer laboratory. The school achieves good quality results. There are six junior secondary schools in the vicinity of this high school.

The second school (School B) is an under-resourced school, thirty-five kilometers from town and ten kilometers from the main road. It is situated in a disadvantaged area and the learners from the school are from poor backgrounds where most of the parents are unemployed. The school has three buildings with six classrooms and two classes per grade. The enrolment of the school is three hundred and fifty with eighty Physical

Sciences learners, forty Physical Sciences learners in grade ten, fifteen in grade eleven and twenty five in grade twelve. The school has fourteen educators and one Physical Science educator who teaches Physical Sciences from grade ten to twelve. The school has no laboratory, no library and no computer laboratory. The majority of the learners live very far from school.

The two schools (resourced and under-resourced school) have similarities. Some of the similarities are as follows:

- They are both rural.
- The learners and educators are all from the same cultural background.
- English is used as a medium of instruction.
- The classes are overcrowded.
- There is a shortage of educators.

### **1.3 The state of science education in South Africa.**

The World Economic Forum (2014) on global information technology reported that the quality of South African education is very low compared to other countries especially with regard to subjects such as Mathematics and Physical Sciences. A number of reports have been written on the state of Physical Sciences and Mathematics education in South Africa. Kriek and Grayson (2009: p.185) reported that 'in 2005 a total of 29 965 learners passed Physical Sciences, in 2006 this figure dropped to 29781 and in 2007 it dropped to an alarming 27122 learners who passed Physical Sciences'. In the 2009 Senior Certificate examination, the national pass rate for Physical Sciences dropped from 55% to 37%. In 2009 the Physical Sciences results dropped in all the nine provinces in South Africa. A Report from the Department of Basic Education (2014) indicated that the percentage pass from 2009 to 2013 for Physical Sciences candidates decreased by seventeen percent.

The Physical Sciences subject is guided by the policies which are drafted by the top managers and curriculum planner of the Department of Education. One of the major complaints that teachers bring forth is that when these policies are drafted the majority of

the people who are at grassroots levels are not consulted. In teacher's discussion forums they identify that this issue leads to the high number of problems within the education system. The schematic diagram below shows the links among the curriculum components.

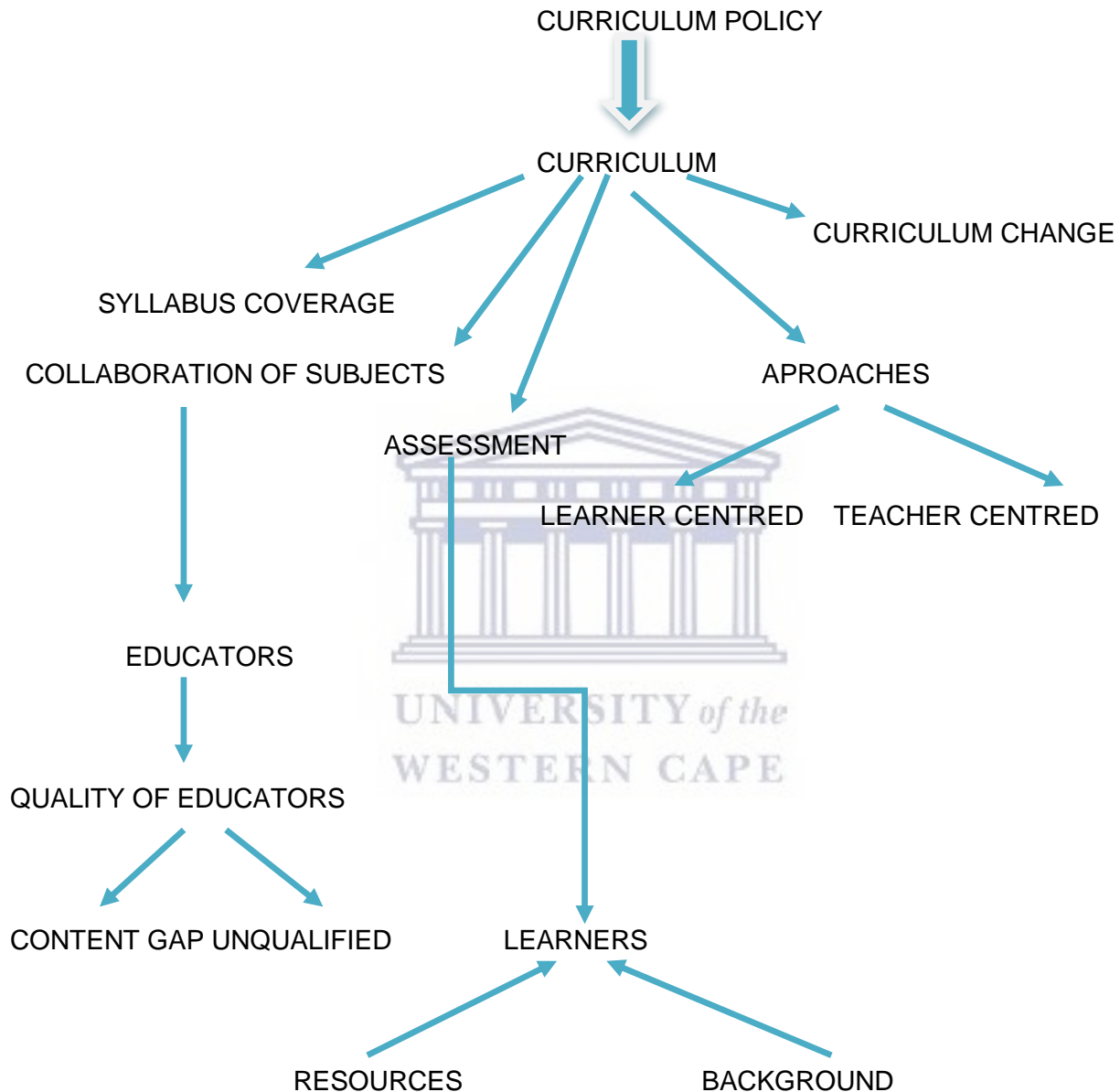

### 1.3.1 Educator qualifications

In the general education and training band (GET) up to Grade 9, learners study Natural Sciences which is composed of a Biology and a Physical Science component. The

researcher found that the majority of educators studied only Biology in their tertiary education. Due to the shortage of educators, an educator is required to teach Natural Sciences. The educators focus only on the Biology component because they never did Physical Sciences at tertiary level. The factor that contributes to poor results in this case is the quality of educator. The educator is not qualified to teach Physical Science because Physical Sciences is not his/her major subject. This results in some of other topics, especially in Physical Sciences part not being taught effectively by the educator because the educator has a content gap. One of the challenges that affect the learners' performance is that they arrive at the Further Education and Training band (FET) level with no Physical Sciences background that was supposed to have been taught in Natural Sciences at senior phase level (grade 7 to grade 9). For example in grade 10, many educators reported that learners do not know even the periodic table. This is due to the lack of proper foundational knowledge.

The educator is the foundation on which the education and schooling of a child is built. The eminence of education in a country is determined by the quality of educators produced in that country. A report by the Organization for Economic Cooperation and Development (OECD) (2005) indicated that factors that need to be considered are that teachers and teaching have a great influence on pupil learning. In particular, their broad consensus was that teacher quality is the single most important school variable influencing pupil achievement. Barber and Mourshed (2007) concurred that the present evidence suggests that the main problem that leads to the disparity in the way the pupil learn at school is the quality of the educators and thus the quality of an education system cannot go beyond the quality of its educators.

### **1.3.2 Assessment policy**

Assessment is a method that is used to evaluate learners' achievement. The criterion that is used to promote learner from grade to grade is very low, which means that many learners are promoted to the next grade without having achieved the necessary understanding of their current grade. There is also a policy of the Department of Education which says that learners must not stay in the same phase for more than four years. Each

phase consists of three grades conducted over three years. At the same time the age of learners is also considered during promotion. That means that learners are promoted to the next phase even if they have failed. These learners are called progressed learners and this carries a negative connotation. This issue leads to poor performance of the learners in Physical Sciences.

### **1.3.3 Teaching approaches**

There are two types of approaches applied in the Eastern Cape schools, namely the teacher- centered and learner- centered approaches. In a learner- centered approach, a learner is an active participant and she/he is responsible for his/her own learning. A learner is able to construct meaning on new information gained using his/her pre-knowledge. In a teacher- centered approach an educator is the source of knowledge, a learner is regarded as an empty vessel which needs to be filled with information. The approach which is better for effective learning is a learner- centered approach but in the majority of schools in South Africa there is a shortage of educators, shortage of resources and overcrowded classes (Akutugba & Wallace, 1999). Due to these factors the educators find it difficult to use a learner-centered approach, overcrowded classes mitigate against the learner- centered approach as it is considered too time-consuming, resulting in its lack of effectiveness.

At science cluster meetings many educators complain that the scope of the syllabus is too broad. There are too many knowledge areas in Physical Sciences in each and every grade. The majority of the educators from the researcher's district highlighted that they have no experience in the teaching of Physical Science and they find it difficult to finish teaching the syllabus within the required time period. The learners enter examinations with some of the topics not covered and learners are unable to provide answers based on those chapters that have not been taught.

### **1.3.4 The scope of the syllabus**

The topics such as acid and the bases, the fertilizer industry and chloro-alkali industry are new grade twelve chapters to some of the educators. The educators find it difficult to

present these topics to learners. The changing curriculum is another factor that affects teaching and learning of scientific concepts. For example, the curriculum changes from NATED 550 to CAPS are as follows:

NATED → OBE → NCS → RNCS → CAPS.

These curriculum changes created confusion in the teaching and learning of Physical Sciences because educators did not receive training as far as the content is concerned.

### **1.3.5 Inadequate facilities to enhance effective teaching and learning**

The majority of the schools have no fully equipped science laboratories and in some schools the laboratories are used as classrooms due to the shortage of classrooms. In South Africa there are few science related institutions which can help in Physical Sciences teaching and learning. There is a lack of accessibility to resources. Physical Sciences is a practical subject that needs learners to be engaged in hands-on practical activities. The majority of learners in South Africa are taught theoretically, in most schools learners are unable to link the theory they are taught in the class to practical application in studying scientific laws.

In those schools which have laboratories, the majority of the educators lack the necessary skills to handle the apparatus. There are no well-trained laboratory assistants who can help the learners and educators in conducting the experiments. In a study conducted by Muwanga –Zake (2006) it was found that in the schools they visited in the Butterworth education district, only five schools out of twenty-five had the Somerset micro science kit and had actually used it. The problem of lack of Physical Sciences resources should be addressed at a higher level in South Africa because it could be an important factor in the poor performance of learners.

### **1.3.6 Lack of teacher support**

There is a need for teacher support by district officials, parents, and the school managers.

Financial support to the schools for Physical Sciences resources is also required, as indicated in the schematic diagram.

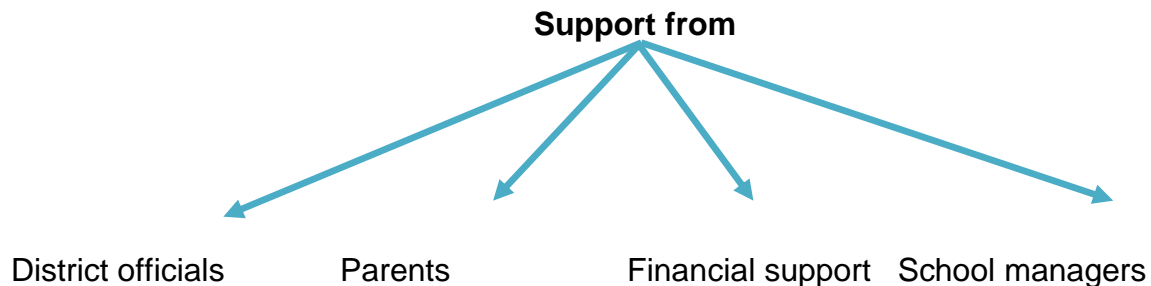

**(a) District officials**

The support that is provided by subject advisors is not sufficient. The subject advisors themselves are overloaded. There is a shortage of subject advisors in the districts.

**(b) Parental support**

There is a lack of parental support especially in rural schools. The majority of the parents are not well educated. The educated parents are not used to the concepts that are used in the new syllabus. The parents are unable to assist learners especially in Physical Sciences because they are not sure about the role they have to play in the education of their children. Even when parents' meetings are held, the attendance is very poor.

**(c) Financial support**

The majorities of the principals have limited knowledge of Physical Sciences and sometimes show no interest in science related issues. When the Physical Sciences educators ask for funds for resources and science equipment, the principal of the school simply refuses to give money to that educator. It is even more difficult to allow learners to go on excursions such as science centers (Grahamstown Science festival).

**(d) School managers**

In many schools in South Africa school managers have no clear understanding about science related issues. The manager treat Physical Sciences on a par with other subjects, neglecting the fact that Physical Sciences is one of the critical subjects that requires learners to be actively involved.

**1.4 Interventions in science education in South Africa and Eastern Cape.**

Over many years there were a number of intervention strategies adopted by the Eastern Cape Education Department with the purpose of improving the results in Physical

Sciences and Mathematics. For grade 12 the focus was on teacher support, the development of resources, supplementary tuition and enhanced assessment interventions. Some of the intervention strategies are as follows:

#### **1.4.1 National Teaching Awards**

The National Teaching Awards (NTA) were launched in 2000. NTA is one of the programmes that is used by the Department of Basic Education to encourage and motivate educators in their work (NTA, 2014). The objective of the ministry of Basic Education through national teaching awards is to recognize and encourage excellence in teaching performance, and to honor committed and effective teachers and schools (NTA, 2014).

NTA is divided into categories. These categories are as follows:

- a) Excellence in primary schools teaching.
- b) Excellence in secondary schools teaching and leadership.
- c) Excellence in grade R teaching.
- d) Excellence in special needs and inclusive technology.
- e) Excellence in technology enhanced teaching and learning awards.
- f) Excellence in Mathematics FET band and in Physical Science FET band and life time achievement awards.

The awards are made at district, regional, cluster and provincial levels. Finalists are awarded certificates of excellence and prizes such as trophies, tablets and laptops.

#### **1.4.2 Dinaledi programme**

Dinaledi is a national programme which aims at teacher development in the Further Education and Training band. The word Dinaledi means 'star'. Some of the schools in the FET band with good grade 12 results in the Eastern Cape Province were selected. The educators from the Dinaledi schools attended content gap workshops during holidays. They received training on how to use Physical Sciences resources and equipment. There are only a few schools in my district which belong to the Dinaledi programme. These schools were supplied with resources like Physical Sciences mobile laboratories with Physical Sciences equipment and laptops containing software for educators and learners.

The Dinaledi programme produces good results but only a limited number of schools with few learners were selected.

### **1.4.3 Science activities**

There are many activities that have been designed to assist Physical Sciences learners, especially the gifted ones. Some of the activities are as follows:

- a) Science Olympiad
- b) Science festival
- c) Science expo
- d) Science clubs.

#### **(a) Science Olympiad**

In the Science Olympiad programme learners are selected in a school to write a test. If the learners pass the test they progress to provincial levels. The top learners are awarded with laptops and certificates.

#### **(b) Science festival**

Activities for the science festival are conducted in Grahamstown. Learners are shown science activities and science related learning approaches. These activities are designed to motivate science learners. The problems with the science festival are that only a few learners are selected and learners have to travel quite a distance to the venue.

#### **(c) Science expo**

The science expo also selects a limited number of learners. These learners present their projects at cluster levels and then at provincial level. There are a number of prizes for those learners who are top achievers.

#### **(d) Science clubs**

The purpose of the science clubs is to make learners and the community aware of scientific issues. They play a major role in introducing people to scientific ideas and in encouraging collaboration and promoting interest in Physical Sciences. The science clubs consist of the following activities: debates, presentations and practical work. However, the majority of the Physical Sciences educators are not familiar with the process of establishing science clubs in their schools and they do not have experience in conducting

the science club activities. There is a great need for support of the educators in establishing science clubs at their schools.

#### **1.4.4 Incubation classes**

Incubation classes were established in 2010 where twenty-five learners were selected in each school in the district. The selected learners are the top ten learners of each school in a district and are taught by the educators with good matric results in the same centre. The educators who teach the learners are called roving tutors.

#### **1.4.5 University of the Western Cape (UWC) programme**

The UWC ACE programme was started in 2010. The Physical Science educators are selected from all over the Eastern Cape Province in each district to attend Physical Sciences classes during holidays. The educators who pass the ACE programme continue to do their Bed Honours in Science Education. Many of these teachers are now doing their Masters in Science Education. One of the key objectives of the UWC is the opening of science club at schools and to equip Eastern Cape educators with skills that enable them to uplift and improve Physical Sciences results in their schools and also in the province as a whole.

Since 2014 the majority of the schools with educators who were in the UWC programme, produced good Physical Sciences results in the National Senior Certificate examination. This programme is funded by the Eastern Cape Department of Education. The skills and the teaching approaches they receive on the programmes play a major role in assisting the educators in their Physical Sciences classes. The improvement in the results showed that the programme has been effective. Furthermore, the effectiveness is evidenced by the fact that the educators are able to use computers in their classes to teach Physical Sciences and deliver various presentations to improve learners' understanding of the content.

In June 2015 a content gap workshop was held at Transkei In-Service Training (TRINSET). The focus was on Natural Sciences educators in the senior phase (grades 7-

9). Science educators were trained on how to conduct Natural Sciences experiments and were equipped with science-related skills. In 2017, 100 educators in the Eastern Cape Province registered for the Advanced Diploma in Science Education and fifty teachers registered for the B.Ed. Honours in Science Education. The programme is being continued as the Department of Education has seen that the programme has produced positive results, with a great improvement in the learner performance in Physical Sciences.

### **1.5 Research problem**

At the cluster meetings that were organized by the subject advisor at the beginning of each year in the researcher's district, the Physical Sciences results were analyzed for each school. There has been no improvement of results in the majority of the schools for the past seven years. The performance of learners in Physical Sciences is poor especially in those questions that require learners' higher order thinking skills. The educators found it difficult to teach some of the topics that were based on practical work because the majority of the rural schools were under-resourced. This was in keeping with the findings of Hofstein and Lunnetta (1982) that in rural schools Science Education results are relatively low due to the shortage of resources. Learners in under-resourced schools find it difficult to do practical work and rather attempt them theoretically for continuous assessment purposes as per departmental requirements.

It is my experience that through participation of learners in conducting experiments themselves, their confidence is built and problem-solving skills are developed. Physical Sciences requires a lot of experimental work which is performed in the laboratory with the use of a variety of science equipment and chemicals. This perception is supported by the Washington National Research Council (2006) report that encourages the development of learners' abilities and understanding with regard to scientific inquiry. They emphasized that there was a need for a fully equipped laboratory in a school so that the learners could do the experiments and could be equipped with problem-solving skills.

## **1.6 Research question**

The study aims to investigate the difference in teaching and learning in schools with resources and those with no resources. In order to identify the differences in teaching and learning of Ohm's law between the two schools, the following research question was posed.

### **1.6.1 Research question**

**How do the teaching and learning of Ohm's Law in Physical Sciences compare in resourced and under-resourced schools?**

## **1.7 Significance of the study.**

This study could raise awareness of different teaching and learning methods in educators to uplift learner performance with particular reference to the teaching of Ohm's law. The study could play a vital role in providing teachers with the recognition and conviction that resources are vital tools in aiding learners to acquire a real understanding of Physical Science's content. The study provides the baseline data with regard to the use of resources in rural schools in science and this data could be used by other researchers as reference, especially in studies that would be dealing with the impact of teaching using resources on learner's performance.

## **1.8 Limitations**

The research was done in two schools in one district, in grade ten classes. The participants selected were very limited in number and do not represent a wider group of learners. The study was conducted in rural schools which do not necessarily have the same environmental factors of urban schools.

## **1.9 Structure of the thesis**

This study consisted of seven chapters. The breakdown of the chapters is as follows:

### **Chapter 1: Introduction**

The first chapter provided the background to the study, consisting of a description of the Physical Sciences results at national, provincial, district and school levels. The context of the schools where the data was collected was also discussed. The state of science

education in South Africa, interventions in science education in South Africa and Eastern Cape were also discussed, leading to the research problem, research questions, significance and limitations of the study.

## **Chapter 2: Literature Review**

Chapter two describes the theoretical framework which underpins the study and reviews studies in the existing literature that are related to this study.

## **Chapter 3: Methodology**

The chapter on methodology includes, research design and the research approaches used to collect the data. The population to be used, site selection and sampling are discussed. This chapter outlines the data collection which consists of the data collection plan and data collection method. Data analysis reports are highlighted. Ethical considerations are reported and the issues of validity and reliability are addressed.

## **Chapter 4: Findings**

Findings from the teacher interviews, learners and teacher observations are provided; the chapter further provides the role played by resources in the teaching and learning of Ohm's law in Physical Sciences. Lastly, the findings from the scores of the test that was written by the learners were noted.

## **Chapter 5: Discussion**

The chapter discusses the findings reported in chapter 4.

## **Chapter 6: Summary and conclusion**

This chapter provides a summary of the major findings of the study and draws the implications and conclusions of the research. Recommendations for future study are suggested.

## **Chapter 7: References**

This chapter consists of the list of all the references that were used in the study.

### **1.10 Conclusion**

This chapter highlights the rationale of the study and some of the problems encountered in the teaching and learning of Physical Sciences. The literature review related to the study and the theoretical framework will be discussed in the next chapter.



UNIVERSITY *of the*  
WESTERN CAPE

## CHAPTER 2

### LITERATURE REVIEW

#### 2.1 Introduction

The literature review explains the definition of some of the terms that are used in the study. The conceptual framework, which provides the key words that are used in the study and conclusion to the chapter is also discussed. Sayser (2014:p.9) highlighted that 'one of the aims of the literature review is to obtain more information about the concept for better understanding' so that the researcher is able to address the research questions. The literature review in this study enables the researcher to have a better understanding of the teaching and learning of Ohm's law in Physical Sciences in resourced and under-resourced schools. Mpofu (2010) added that the aim of the literature review is to find out what other people say about the study of those concepts that are relevant to the study. This chapter provides an understanding of the topic that will allow the researcher to address the research question. Henning, van Rensburg and Smith (2004:p.26) maintain, 'the purpose of the literature review to argue a case, to synthesize the literature on the selected topic and to engage critically with it'. A theoretical framework assists the researcher in accomplishing the aims of the study.

#### 2.2 Definition of terms

**Laboratory** is the place where science equipment is kept and it is where the experiments are done. Mhlongo (2010) defines laboratories as 'wonderful venues for teaching and learning science'.

**Practical activities** are those activities that enable the learners to be hands-on, doing experiments themselves, which include practical demonstrations, experiments and projects that are done in an institution to equip learners with problem- solving skills, data collection skills and data interpretation skills.

**Practical work** is whereby learners learn by interacting with materials in the laboratory so as to encourage accurate observation to draw conclusions (Lunetta Hofstein & Clough, 2007). Millar (2004) refers to practical work as 'any teaching and learning activity which at

some point involves the students in observing or manipulating real objects and materials they are studying’.

**Physical sciences** is the branch of science that describes the information gained using experiments and focuses on investigating physical and chemical phenomena through scientific inquiry.

**Experiments** are all the steps that are followed by the learners so as to obtain the results for the law or theory that is being verified. .

**Ohm’s law** is the law in electric circuits which indicates the relationship between potential difference and current. The law states that the current in a metallic conductor is directly proportional to the potential difference across the ends provided that temperature remains constant.

**Resourced school** is a school that provides opportunities to increase both the quality and the effectiveness learning programmes by ensuring that the learners are given opportunities to succeed and helps them to open up to reality by using resources that will help them grasp and interpret reality.

**Under-resourced school** is a school with inadequate or no laboratory equipment, where the teacher centred approach is used and the content is taught theoretically in most of the times.

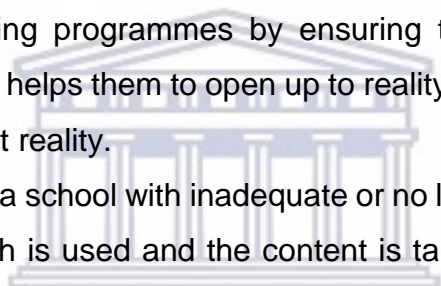

UNIVERSITY of the  
WESTERN CAPE

### 2.3 Research question

This study is directed at answering the following main research question:

How do the teaching and learning of Ohm’s Law in Physical Sciences compare in resourced and under-resourced schools?

### 2.4 Theoretical framework

Constructivism is the theory that underpins this study. Constructivism is the process of construction of meaning and knowledge by the learner and is based on how knowledge is built in the mind of the learner using the information that already exists in the mind of the learner. The construction of knowledge results in more learning and each learner can go beyond the material that is presented and can process the information so that it can be easily understood (Philips, 1995). Constructivist theorists assume that the learner is

not a blank slate; he/she has his or her existing prior knowledge. They continue by saying that a learner has to link his or her existing prior knowledge to the new knowledge gained in the classroom so as to construct the meaning. Leach and Scott (2002) added by saying that an educator has to take into consideration the learner's existing understanding so that the new knowledge can be built upon the learner's prior knowledge.

Dhurumraj (2013) pointed out that learners are supposed to be given activities that keep them active at all times, instead of giving them knowledge that will allow them to memorise. He further added that learners must be engaged in the activities that allow them to be 'hands-on' so that they can be actively involved in the process of their learning in order for them to have a better understanding. Hands-on activities are the practical activities that enable the learners to do experiments themselves using all the senses, especially the senses of touch, smell and sight. This means that in the presence of the resources in a school the learners can conduct experiments themselves using those available resources.

The constructivist approach to teaching indicates that the teacher's role is to act as a catalyst to speed up the learning process and the learners react to that catalyst by learning on their own and finding the meaning of what is taught by the educator (Rankhumise, 2012). Learners use methods which are based on the knowledge they have to solve problems in society (Muwanga-Zake, 2006). Terhart (2010) suggested that existing knowledge is the starting point for any interpretation of the pieces of information that lead to learning as a construction of knowledge.

A learner must change his or her 'mental models' to provide accommodation for the new experience so as to learn more (Johannes 2005). A mental model is how a person understands things around him or her using his or her own explanation so as to acquire the meaning. In order for a learner to understand the concept, learning must start with simple concepts which are found in the learner's environment (everyday knowledge) (Hartley, 2013). His statement concurs with that of Johannes (2005) and further

highlighted that intellectual models used by the learner need to be understood first before teaching new knowledge.

For a topic which is based on Ohm's law, a learner must use his/her prior knowledge of proportionality, electric circuits, parallel and series connection and charges so as to make connections with the new topic. This means that the educator guides the learners using examples from previous topics from previous grades and learners' everyday knowledge that is relevant to the topic, so that they can understand the concept in order to construct their own meaning. For the Ohm's law concept, if learners are able to understand the meaning of the law, they will be able to use and apply the law to their environment and in the outside world when they deal with electricity. Learners can become aware of the fact that when they increase the number of cells they are increasing the potential difference that will result in an increase in current. Having that knowledge in mind, learners can become problem- solvers of electricity related problems and can solve the problem of shortage of electricity in the world.

Ausubel (1963) stated that learning occurs when learners find meaning in new information by making connections with their existing knowledge. Learners can work independently or as a group to obtain new knowledge. Knowledge is an idea that is constructed in the mind of a learner (Robottom, 2004). He further signposted that learners use their own opinions, understandings and thoughts to understand the information being taught by the educators. Asan (2007) cited that constructivism plays an important role in the science classroom. An individual's knowledge is self-organized through various mental associations and structures (Okanlawon, 2012).

In the laboratory, learners learn by using all their senses to observe the outcomes of the experiment and this makes learning possible. Learners are dealing with concrete things, according to the stages of Piaget's theory. Piaget mentioned assimilation and accommodation for context development (Blok, 1982). Piaget indicated that there is a relationship between assimilation and constructivism because in both concepts learners

are given a chance to interpret data so as to draw conclusions. Each learner is able to gain meaning of knowledge using different approaches and the educator has to take control of what he/she teaches and allow the learners to learn at their individual pace. The learners learn as they do the experiment on their own and think critically so as to interpret the data collected (Lowery, 1994).

The search for understanding motivates the students to learn. When the learners want to obtain more information about a notion or a topic, their reasoning revolves around the investigations and discussions which occur in the classroom and they study more on their own (Grennon Brooks & Brooks, 1993). When the learners do a practical to investigate a law in the laboratory they are actively involved in the process of their learning. This is in line with Coleman's (1997) statement which pointed out that when an educator is teaching Physical Sciences the focus should be directed towards facilitating active learning among learners. The educator gives the learners problem-solving activities that will allow them to learn by discovering (Goodwin, 2014). For learners who are taught Ohm's Law theoretically only, the learners are passively listening to their educator and the educator is using a teacher-centered approach.

As far as constructivism is concerned, Piaget (1976) and Vygotsky (1978) agreed with each other because they suggested that for learning to be effective, learners must be the active participants in the process of their learning so that they can better understand the topic. If the learners have understood the topic they have a greater ability to explain the topic using their own words. They further state that the topic taught must be in line with the level of development of the child.

#### **2.4.1 The impact of constructivism on learning**

Atherton (2011) emphasized the "active involvement" of a learner in the learning process. Powell (2013) talked of the effective classroom and defined it as a classroom where there is maximum communication between the educator and learners. The effective classroom is governed by the use of the constructive strategies which are employed. The impact of constructivism on learning is based on curriculum, instruction and assessment (Hartley,

2013). Constructivism is based on three concepts and the concepts are presented in Table 2.

**Table 2:** The three concepts on which constructivism is based (Hartley, 2013)

<b>Curriculum</b>	<b>Instruction</b>	<b>Assessment</b>
<p>Constructivism calls for a curriculum that encourages learners to do practical activities themselves so that the learners can draw conclusions and become problem solvers.</p>	<p>Educator's duty is to link the new knowledge to what the learners already know about the concept. To probe the learners' understandings, an educator asks simple questions that will allow the learners to express themselves as much as they can. An educator also creates a space for learners' interaction and for learners to ask questions as often as they can. With the Ohm's law concept an educator has to give learners a chance to collect the data when the batteries are added to the circuit, note the ammeter reading and the voltmeter reading. After they have collected the data they analyse and interpret the data so as to draw conclusions. The conclusion enables the learners to state the relationship between potential difference and current.</p>	<p>Constructivist theorists advise that assessment must not be separated from learning so that a learner can see his or her 'own progress' (Hartley, 2013). For a lesson which involves practical work there are work sheets with questions that are given to learners. As the learners do the practical work they also fill in the answers in the work sheet. The educator will immediately see whether the learners understood the topic or not through the assessment that is done continuously. This is in line with the curriculum and assessment policy statement which indicates that the assessment must be continuous and can be formal or non-formal.</p>

Constructivism is divided into two types:

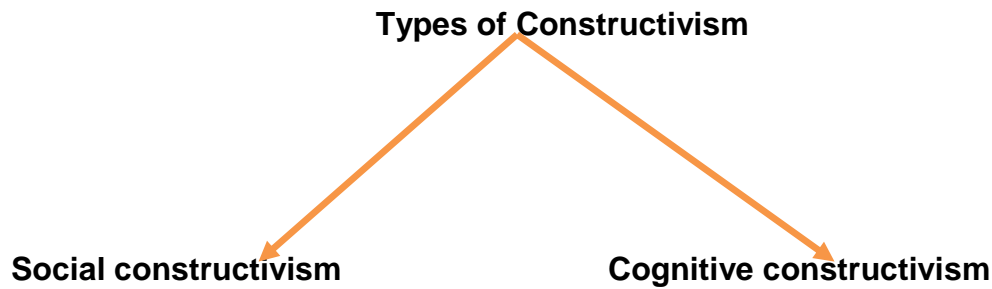

Atherton (2011) described two types of constructivism namely: cognitive constructivism and social constructivism. He defined cognitive constructivism as a form of learning whereby things are understood and interpreted according to the stages of development and the learning styles of learners. Romanell (2009) highlighted a benchmark definition of learning style as a specific cognitive, operative and psychological actions that serve as comparatively unchanging signs of how learners recognize, intermingle with, and respond to the learning environment. In cognitive constructivism, notions are created in individuals through individual progressions (Powell, 2013).

Social constructivism is where learners try to understand everything in their society through knowledge construction (Derry, 1999). Kim (2011) indicated that social constructivism is grounded on specific expectations about authenticity, knowledge, and learning. All the things that are done by humans indicate reality and meaningful learning occurs when individuals are involved in social events (Kim, 2011). The learners must be equipped with skills that will be used in society so that they are able to fit into it. This means that the school curriculum should be designed in such a way that it can address the needs of the society (Eisner, 1985). Social constructivists emphasize the importance of culture and environment on the learning process. The basis of the theory of social constructivism assumes that reality is constructed through human activity, knowledge is created through interactions with others, and their environment and learning is more meaningful when the learner is socially engaged.

Four perspectives of social constructivism include: cognitive tools perspective, ideas based on social constructivism, the pragmatic or emergent approach, and transactional or situated cognition. Social constructivism ideas are established from Vygotsky's theory and all of its language features (Powell, 2013). The learner uses the knowledge imparted by the educator to 'generate his or her own meaning of the content' (Dunnie, 2013.p.12). Dunnie (2013) mentioned radical approach as one of the approaches to constructivism. This approach is based on Piaget's work. Radical constructivism indicates that knowledge development occurs, provided that the knowledge is true. The learner constructs knowledge and truth which is based on social interaction (Mathews, 2008).

In a classroom situation, learners must work hand in glove with their educator and with each other so as to promote cooperative learning. This means that learners are actively engaged in the process of their learning through dialogue which promotes critical thinking in the learners. That is the reason why currently in Physical Sciences there are programmes such as science debates, science expos, miniquizzes, presentations and competitions where learners do the research about phenomena in their society, relating and linking them to the topics that are taught in the school. Cooperative learning is part and parcel of social constructivism. After the learners have shared the ideas, knowledge 'internalization' will take place in each learner (Vygotsky, 1962). Some theorists claim that social constructivism and situated learning confirm Vygotsky's notion that learning is inherently social and rooted in a particular culture (Woolfolk, 2004). In social constructivism an educator acts as a facilitator of knowledge and learners as active constructors of knowledge.

Brooks and Brooks (1999) concluded by indicating five central tenets of constructivism. These tenets are as follows:

1. Constructivist teachers search for the learners' opinions and take them into consideration so as to show their importance. When the educator knows what the learners think about the concepts, he or she is able to plan lessons based on the interest and needs of the learners. This means that when an educator introduces a lesson he or she

must start from the known to the unknown, from simple to complex and from concrete to abstract.

2. Constructivist teachers organize their lessons in a way that will give the learners a chance to think about the concepts. This implies that all learners, regardless of their age or background, come into class with prior knowledge that is necessary and will assist in the process of teaching and learning. Learning occurs when the educator allows the learners to come up with their views about the concepts. The educator can ask the learners some questions which are relevant to the topic that will help the educator to check the level of understanding of the learners. The prior knowledge that the learners have will help the educator to link the new topic to what the learners already know.

3. Constructivist teachers must ensure that the learners make links within the curriculum. The learners become more interested as they note the importance of their day- to- day activities. The learners must be able to link the school knowledge with everyday knowledge.

4. Constructivist teachers organize the lessons around whole concepts. When the learners are exposed to whole concepts, they are able to determine the small parts that together constitute those concepts. In Ohm's law an educator introduces the topic by giving the statement of the whole law and then explains the law by relating the topic to the small parts such as resistors, cells, connecting wires, ammeter, voltmeter and resistance.

5. Constructivist teachers assess the learners continuously and daily. Learners show what they know in the form of presentations, answer questions orally or as written tasks. This means that the learners must be assessed continuously using different forms of assessment. Furthermore Taber (2006) in his analysis came up with seven core ideas of constructivism. The ideas are as follows:

a) A learner is responsible for his/ her own learning, understands and finds meaning that is based on knowledge constructed by him/ her.

- b) A learner comes into class with some of the knowledge that will help him/her to understand the new knowledge gained in the class. .
- c) Each learner has his/her own understanding about the world with so many ideas.
- d) Some ideas cannot be easily changed without understanding and conviction.
- e) The new concept that is taught must be based on the learners' prior- knowledge in order for teaching and learning to occur.
- f) There must be a relationship between the knowledge gained from the school and the learners' environment so that the learners can be able to construct their knowledge.
- g) A learner has to keep knowledge gained in his or her long- term memory.

## **2.5 Conceptual framework**

### **2.5.1 Studies that are related to the concepts used in the study.**

There are many problems that face science education in developing countries (Dzama and Osborne 1999). They noted poor performance as one of those problems which is caused by the lack of a 'supportive environment' that will allow the learners to be actively involved. Furthermore, there is also a problem in developing countries which is caused by the shortage of science equipment and motivated educators who are well-trained in science equipment usage (Prophet, 1990).

### **2.5.2. Teaching and learning.**

Teaching and learning are two words that are closely related to each other. Teaching is defined as the quality of learning promoted that will allow learners to search for meaning, and make sense of their learning (Biggs, 2003). Learning is the change in behavior that results when the new experience is accommodated by the adjustment of the mental models of learners. Learning is also defined as a process whereby learners are given activities so that they can construct their knowledge using previous ideas.

There are seven principles which play an important part in teaching and learning (Donald, Lazarus & Lolwana, 2010). Mkonto (2010) lists the seven principles as follows:

1. Process as well as content:

Learners must know the meaning of what they are learning in order for them to understand the content.

2. Active learning:

Teaching and learning should allow learners to be enthusiastically involved in the process of their learning. This means that for teaching and learning to be effective, learning by doing is stimulated.

3. Connecting familiar to unfamiliar:

The new knowledge gained in the process of teaching and learning must be linked to the learners' existing knowledge (from known to unknown). This means that when an educator teaches Ohm's law he or she must first ask questions that are based on everyday use of electricity in their homes and relate them to the Ohm's law concept.

4. Guided discovery:

Aims and objectives of the lessons must be clearly defined. In the process of teaching and learning, learners must be taught and guided so as to achieve the objectives of the lesson.

5. Scaffolding:

Scaffolding is the process whereby the educator gradually minimizes the level of assistance to the learners as he or she proceeds with the lesson, so that a learner can work at his or her own pace and solve problems (Vygotsky, 1978). The purpose of scaffolding is to promote independent learning so that the learner does not depend on the educator at all times (Mkonto, 2010). An educator teaches the learners in such a way that they can be able to search for the information themselves, applying the information gained from the educator in the classroom.

6. Group work and cooperative learning:

Group work allows learners to interact with each other, sharing ideas and helping one another to achieve the objectives.

7. Language interaction:

Language plays a vital role in the process of teaching and learning. The learners must be given a chance to participate in activities like discussion, reflection, debate and interactive problem-solving (Mkonto, 2010). When the learners are conducting experiments,

especially the investigation of the law, appropriate language is used to communicate findings.

For teaching and learning to be effective, a learner must listen to what the educator teaches and in order for the learner to be well equipped with information he/she must go further by reading the concept or information taught about the topic. The educator must use 'heuristic' approach to teaching. The heuristic approach to teaching is the approach that was proposed by Wesi (1997). According to the heuristic approach to teaching, the learners are taught science so that they can discover knowledge and information themselves ( Wesi,2001).To see whether the learner has understood the topic he/she must be assessed and the learner has to respond to the questions according to what he/she has been taught. There are different forms of assessment; assessment can be formal, it can also be informal. Examples of informal tasks in Physical Sciences are experiments, class tests, practical investigations, class work and homework (Department of Basic Education, 2011). Formal assessments include controlled tests, examinations, experiments and projects.

### **2.5.3 Physical Science and its aims**

The Department of Basic Education (2011: p 8) defines Physical Sciences as a subject that 'examines physical and chemical phenomena through scientific inquiry, application of scientific replicas, theories and laws in order to clarify and predict events in the physical environment'. Physical Sciences is concerned with everything that is within the learner's environment and everyday knowledge. Physical Sciences is taught so as to develop the science process skills (Mkandawire 2009). Science process skills are the 'sequence of events which are engaged by researchers while taking part in a scientific research investigation, and are generally related to the application of cognitive and investigative skills'. (Arena, 1996.p.34). The process skills are listed as follows: observing and comparing, measuring, recording information, sorting and classifying, interpreting information, predicting, hypothesizing, raising questions about a situation, planning science investigations, conducting investigations and communicating science information (Department of Education 2002).

The purpose of Physical Sciences is to familiarize the learners with their environment and equip them with investigating skills related to physical and chemical phenomena (DoE, 2011). Physical Sciences skills are: 'categorizing, communicating, measuring, designing an investigation, drawing and evaluating conclusions, formulating models, hypothesizing, identifying and controlling variables, inferring, observing and comparing, interpreting, predicting, problem-solving and reflective skills'(Curriculum and Assessment Policy Statement, 2011). CAPS highlights that Physical Sciences plays a major role of promoting 'knowledge and skills in scientific inquiry and problem solving'. The knowledge gained in Physical Sciences enables the learner to solve problems within the society.

The national curriculum statement (NCS) which deals with outcomes-based education (OBE) encourages the educators to be the facilitators who guide the learners in the process of their learning. The emphasis is on giving the learners the activities that will allow them to search for information and come up with solutions so that they become problem solvers. The Department of Education (2006) stresses that there must be a shift from a teacher-centred approach to a learner-centred approach. In the OBE approach the Physical Sciences curriculum was based on three learning outcomes (LOs). The three learning outcomes are described as follows:

1. Practical scientific inquiry and problem solving skills, 2. Construction and application of scientific knowledge. 3. The nature of science and its relationships to technology, society and the environment (DOE, 2003). To establish whether the learning outcomes are achieved, the assessment standards were introduced. The learning outcome number 1 has 4 assessment standards, learning outcomes number 2 and 3 each has 3 learning outcomes. The 3 learning outcomes and the assessment standards are summarized in table 3.

**Table 3: Assessment Standards (ASs) of each Learning Outcome (LO) of the NCS FET curriculum (DOE, 2006)**

Learning outcome	Assessment standard
LO 1 Practical scientific inquiry and problem solving skills	AS1: Conducting an investigation  AS2: Interpreting data to draw conclusions  AS3: Solving problems  AS4: Communicating and presenting information and scientific arguments
LO2 Constructing and applying scientific knowledge	AS1: Recalling, stating and discussing specified concepts  AS2: Indicating and explaining relationships  AS3: Applying scientific knowledge
LO3 The nature of science and its relationships to technology, society and the environment	AS1: Evaluating knowledge claims  AS2: Evaluating the impact of science on human development  AS3: Evaluating the impact of science on the environment and sustainable development.

According to Table 3, learning outcome number 1 deals with the skills acquired by the learners in the laboratory when doing a practical work and they are assessed based on those skills. Learning outcome 2 is about the application of the skills that the learners acquire when doing practical work using the resources and learning outcome 3 is about the application of the knowledge gained by the learners from the classroom to the society.

As it has already been indicated by some of the researchers that the majority of the schools have no resources, educators teach the learners using the teacher-centred-

approach. In the absence of Ohm's law apparatus in under-resourced schools an educator can teach the learners the relationship between the potential difference and current using the examples from the text books. In those schools with apparatus, learners can conduct the experiments themselves using the Ohm's law apparatus under the educator's supervision.

In CAPS it is emphasized that the Ohm's law experiment must be done as one of the recommended experiments for formal assessment. When the Ohm's law experiment is undertaken in the laboratory there are certain steps that are followed. The steps are as follows: aim of the experiment, data collection, observation, data interpretation and drawing conclusions (Lazarowitz, 1998 & Toplis 2012). Kibirige and Hodi (2013) stress that the laboratory investigations must be done so that the learners can understand laws and theories and be able to apply them in real life situations so that learning can become meaningful. Ottander and Grelsson (2006) further noted that when the learners do practical work, critical thinking skills are developed and the learners become interested in Physical Sciences.

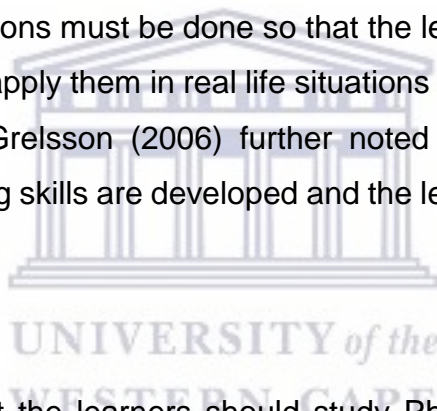

The researcher advised that the learners should study Physical Sciences at an early stage so that they can have a positive attitude and have confidence in choosing science related studies and careers. Physical Sciences is one of the most important subjects in the Further Education and Training band (FET) considering that in the majority of secondary schools, Physical Sciences is offered as a major subject. Even at university level Physical Sciences is one of the main subjects that is recommended even if the career is not science related.

#### **2.5.4 Physical Sciences and active learning**

Physical Sciences is a subject that provides learners with scientific knowledge and scientific knowledge is the basis of Science Education. Dadach (2013) outlines different strategies that keep the learners active at all times in the teaching and learning process. One of those strategies is 'inductive learning'. He stipulates that the experiments that are done in a laboratory allow the learners to work as a group and teach them how to carry out experiments in a safe manner, collecting data using an investigative strategy, analyzing experimental values, comparing the findings with the theory and presenting the results.

Active strategies are encouraged when Physical Sciences is taught (Dhurumraj, 2013). Active learning is a method of acquiring knowledge by using concrete objects (Harrington & Terry, 2009). These strategies involve active learning which is the procedure that is followed in acquiring knowledge or skills by involving the learners in activity-based programmes (Harrington & Terry, 2009). Dhurumraj (2013) defines active learning as a type of learning whereby an educator and a learner learn from each other. His definition of active learning is in line with that of an Outcomes Based Approach which indicates that learning must be a two-way process. Dale (1969) stated that active learning occurs when the learner is 'actively involved' in the process of his learning.

The active learning of a learner is caused by the active teaching of a teacher which can be noted when an educator explains concepts clearly and allows learners to ask and answer questions correctly. Woolfolk (2007), indicated that active teaching is characterized by high levels of teacher explanation, together with demonstrations and student interaction. If the learners' achievement improves and learners obtain good results, this means that the teaching has been effective (Dadach, 2013). Dadach concurs with Michel (2009) who emphasized that there is a better understanding in a class where learners are actively involved. In a Physical Sciences classroom, active learning can be promoted when an educator gives learners an opportunity to read the chapter first and allows the learners to work on a presentation before teaching the chapter. The educator

has to present the lesson in such a way that it can allow learners to do the investigation, collect data, analyze and interpret the data so as to draw conclusions (Woolfolk, 2007).

There are varieties of activities that can be done in active learning and there are also some benefits. The activities are problem- based learning and laboratory experiments (Dadach, 2013). He further mentioned some of the benefits of active learning. The benefits are as follows:

- a) Maximum participation of learners
- b) Engagement of higher order thinking skills such as analysis, synthesis and evaluation
- c) Increased intrinsic motivation. The intrinsic motivation could be enhanced by the teacher employing a 'deep approach to teaching' where an educator relates the new experience to the learners' prior knowledge.

Dhurumraj (2013), in his research study which is based on the contributory factors to poor learner performance in Physical Sciences, mentioned the lack of resources in schools and homes in the teaching and the learning of the Physical Sciences which can affect learner performance. He further highlighted that in many public schools in South Africa, there is a lack of proper laboratory facilities; thus learning Physical Sciences can become very difficult for learners. I strongly agree with the above statement because the only resources that the majority of the schools have are text books and Physical Sciences is taught theoretically using the "telling" method. Thus the educators are unable to give the learners a chance to do the experiments themselves (Mchunu, 2009). Due to the absence of resources, Physical Science topics are taught theoretically and the learners find difficulties in applying the knowledge, so Physical Sciences becomes a theoretical rather than a practical subject (Makgato & Mji, 2006:254).

Dhurumraj (2013) summarizes his findings by saying that 'the availability of equipment for the practical aspect' is very important so that the learners can be in a position to understand the knowledge gained and apply it to other situations. One of the principles of OBE is learning through hands-on experience but in under-resourced schools this

principle is not applicable (Dhurumraj, 2013:p.61). Ohm's law is one of the topics in Physics that can be taught experimentally using Ohm's law apparatus and also can be taught theoretically. Ojediran, Oludipe and Ehindero (2014) pointed out that the laboratory should help the students to handle and use the apparatus, collecting the data based on the concepts they are investigating. Observation and presentation of the outcomes leads to greater understanding of the concepts.

The laboratory is seen as a place where active learning occurs (Ojediran et al, 2014). In the laboratory, using the correct equipment, the learners do the experiments themselves and interact with each other. The purpose of laboratory practice is to enable the learners to develop competency in observation when the experiments are conducted (Morgil, Gungor, &Secken, 2009).

Practical work in the laboratory encourages students to approach problems and solve them, to discover the facts and principles, to develop an ability to cooperate and develop a critical attitude towards the subject (Ojediran et al., 2014). The educator in the laboratory plays an active role by organizing a learning space and materials that enable all the learners to be productively engaged in individual and cooperative learning. The learners are thereby actively involved and free to exchange ideas. Ojediran et al (2014) concluded that 'the use of laboratory based instructional intervention method of teaching should be embraced as a good asset to Physics students and teachers in the senior secondary schools'.

### **2.5.5 The Teaching and learning of Ohm's law in Physical Science**

The Physical Sciences syllabus in grade 10 is divided into two categories, Physics and Chemistry. Physics consists of three modules: mechanics; wave sound and light; electricity and magnetism. One of the topics in electricity and magnetism is electric circuits, which deals with the Ohm's law concept. This is the law which indicates the relationship between resistance, potential difference and current. For this topic to be

understood by the learners, the educator can teach it using teacher-centred or learner-centred approaches.

McDermott & Shaffer (1992) referred to the teacher-centred approach as traditional Physics instruction. They further stated that the approach is used in many Physics classes and the concepts and materials are presented and taught using a lecture-type method. The learners absorb the information passively.

McDermott & Shaffer came up with the following findings about the telling method:

1. The 'Telling' method is an ineffective mode of instruction for introductory Physics regardless of the brilliance and skill of the lecturer. Students need to be intellectually engaged in order to develop a fundamental understanding.
2. A student who has achieved facility in the solving of standard quantitative problems has not necessarily achieved functional understanding of Physics concepts. Such a student may be unable to answer questions that require qualitative understanding and verbal explanation.
3. Certain conceptual difficulties with which students enter introductory physics courses (e.g. that a battery is a constant current source) are not overcome by traditional instruction, and persist unless they are explicitly and repeatedly addressed.
4. Students enter introductory Physics courses without a coherent conceptual framework, but traditional instruction does not typically cause them to develop one. Unless students participate in the construction of qualitative models, they do not come to understand the relationships and differences among concepts.
5. Growth in the ability to reason scientifically does not usually result from traditional instruction, but must be specifically cultivated.
6. After traditional instruction, students typically still lack connections among concepts, formal representations (equations, graphs, diagrams), and the real world. They need repeated practice in interpreting Physics concepts and relating them to the physical world.

Qhobela and Moru (2011), in their research study, recommended that the learning of Physics through argumentation at secondary school level in Lesotho in an effort to encourage a shift from a teacher-centred approach to a learner-centred approach.

Ohm's law is the law which indicates the effect of potential difference on the current which passes through the conductor, discovered by George Simon Ohm (Rankhumise, 2012). Ohm's law states 'the current in a metallic conductor is directly proportional to the potential difference across its ends provided that temperature remains constant'. Proportion is described as the relationship between two variables: the dependent and the independent variables. Kelder (2012) defines direct proportion by saying that the variables are directly proportional when the increase in an independent variable results in the increase in the dependent variable. This means that in Ohm's law an increase in potential difference results in an increase in current if the temperature remains constant. Potential difference is the independent variable, current is a dependent variable and temperature is a control variable. Mathematically Ohm's law is written as follows:  $V \propto I$ .

To verify Ohm's law an educator can conduct the experiment or practical work with the learners in the laboratory using Ohm's law apparatus. The main purpose of engaging learners in laboratory practices is to encourage the achievement of the Science Education goals. The secondary and ultimately more meaningful purpose is to improve students' understanding of concepts in science and its applications; scientific practical skills and problem solving abilities; scientific 'habits of mind'; understanding of how science and scientists work; interest and motivation (Hofstein & Mamlok-Naaman, 2007). Awotua, Williams & Aderonmu (2015) indicated the importance of practical activities in Physics. They pointed out that practical activities enable learners to make links between what they see, hear, handle (hands-on), and scientific ideas that give descriptions for their observations (brains-on). They further pointed out that no meaningful Physics principle or concept can be taught without adequate practical activity accompanying such presentation using appropriate practical apparatus. To indicate the relationship between potential difference and current, Ohm's law apparatus are used. These consist of

batteries, circuit board, conductors, resistors, ammeter, voltmeter, switch and crocodile clips. In the absence of Ohm's law apparatus, an educator can use resources such as text book, videos and charts.

#### **2.5.6. The teaching and learning of practical work in resourced and under-resourced schools**

According to Musasia, Abacha & Biyoyo (2012), the training in handling Physics practical lessons has been ineffective in many developing countries including Kenya. They were supported by Onwioduokit, Adolphus & Aderonmu (2013) who stated that in most schools Physical Sciences is taught theoretically due to insufficient laboratory facilities. The learners memorize the information being taught by the educator and this could result in rote learning.

Internationally, some schools are resourced and others are under-resourced. Resourced schools are those with sufficient teaching and learning materials and laboratories. Under-resourced schools are those with no or insufficient materials and laboratories. Kibirige & Hodi (2013:p.42) regard Nigeria as one of those countries with insufficient laboratory facilities. Generally, guided discovery notes are used to teach Physics learners in secondary schools, supported by demonstrations and expository teaching approaches.

In Limpopo Province Science educators teach learners using a teacher-centred approach because the schools are under-resourced (Onwu & Stoffels, 2005). Mhlongo (2010) highlighted that many learners do not participate in the experiments due to overcrowded classes. He further mentioned that the apparatus that are available are not sufficient. Some research reports indicate that the majority of the physics topics are taught using the chalk and talk method (Qhobela & Moru, 2011; Maqutu, 2003).

The teaching and learning of the majority of the science topics 'demand' the use of 'adequate' resources that are used to do practical work (California Department of Education, 2004). Practical works are the 'hands-on' experiments that are done by the

learners so as to get answers to certain questions (Kim & Chin, 2011). Millar (2004.p.22) defined practical work as 'any teaching and learning activity which at some point involves the students in observing or manipulating real objects and materials they are studying'. Millar further indicated that an educator can perform demonstrations for practical work or learners can do practical work themselves. Woodley (2009,:p.9) concurred with Millar (2004) and Kim & Chin (2011) with regard to the definition of practical work and he added that practical work must be included as a 'hands-on learning experience' that enable the learners to think about everything around them.

Ngema (2011) highlighted the fact that the word 'laboratory' or 'practical' have similar meanings based on a similar viewpoint irrespective of the use of the term practical or Laboratory work. Ngema (2011) further defined practical work as the teaching and learning approach that will enable learners to develop process skills and also enhance their understanding of concepts, laws and theories of Physical science. Practical work can be done in the school laboratory or outside the school environment. Laboratory is defined as a place where someone does an investigation of a natural phenomenon (Dreckmeyer, 1994).

### **2.5.7 Further studies that are related to teaching and learning in resourced and under-resourced schools**

There are precautions that must be considered when doing laboratory experiment so as to obtain more accurate results. Experiments should be conducted if the relevant resources are available for that particular topic. The experiments are done to verify the laws so as to indicate the relationship between concepts. In any topic that is based on electricity, practical work must be undertaken to develop investigative skills and an understanding of challenging objects or phenomena. Kolucki & Lemish (2011) highlighted that practical work is done in science so that the learners can gain a better understanding. Hampden-Thompson & Bennet (2013) agreed by saying that when practical work is done the learners are actively involved in the process of their learning and they gain more knowledge through hands-on activities.

Learners learn in different ways when experiencing practical work. The different ways are experiential, independent, team and peer dialogue (Zimbardi, Bugarcic, Colthorpe, Good & Lluka, 2013). In schools with sufficient Physical Sciences resources a learner can do experiment on his or her own but in those schools with few resources or no science resources, learners can work in groups. In studies conducted by Mavhunga (2014:p.157) it is indicated that learners who are able to conduct practical work perform better than those who are taught theoretically. Many problems face South African educators in under-resourced schools, one of which is that the majority of the educators are themselves a product of an education system that did not allow them the opportunity to do experiments when they were at school (Bradley & Smith, 1994).

Electricity is an important and necessary topic in science education (Moodley, 2013). Electric circuit topics consist of textbook-based instruction and practical, hands-on lessons (Kolloffel & Jong, 2013). In textbook-based instruction, learners are taught definitions of terms, laws, equations that can be used to solve problems, and are shown how to draw a circuit diagram (Frederiksen, 1997, White & Gutwill, 1999; Gunstone, Mulhall & Mckittrick, 2009; Jaakkola, Numi & Veermans, 2011; McDermott & Shaffer, 1992). The terms in the electric circuit topic are Ohm's law, electric current, potential difference, and resistance. Equations are  $R_T = R_1 + R_2 + R_3$ ,  $1/R = 1/R_1 + 1/R_2 + 1/R_3$ ,  $R = V/I$ .

In a practical lesson learners work with real equipment (resistor, ammeter, voltmeter, cells and connecting wires), build electric circuits themselves, connect ammeter, voltmeter and connecting wires themselves, and take the readings on the ammeter and voltmeter. Using the data they have collected, learners note the relationship between the potential difference and current. Thus, for the better understanding of Ohm's law, textbook – based lessons must be linked with practical hands-on lessons (Kolloffel & Jong, 2013).

If the learners have understood the lesson, the goals and objectives of the lesson can be achieved. Physics learning goals that have been attributed to laboratory experience include: enhancing mastery of the subject matter; developing scientific reasoning, understanding the complexity and ambiguity of empirical work, developing practical skills,

understanding the nature of Physics, cultivating interest in Physics and interest in learning Physics; and developing teamwork ability in solving problems(National Research Council, 2006).

Tobin (1990) reported that laboratory activities are an alluring and interesting way to learn with understanding whilst at the same time engaging in a process of constructing scientific knowledge by hands-on activities. Laboratory work aims at giving the evidence of the existing laws (Roychoudhury, 1996). For Ohm's Law experiments in resourced schools experiment is done in the laboratory using a science kit. MacDonald & Rogan (1998) highlighted that in some schools that have a shortage of science equipment learning is demonstrated. In schools with adequate science laboratory resources learners conduct practical works themselves with the help of instructions from the educator (Fisher, Fraser & Henderson, 2007). A Microcomputer-based laboratory enables learners to collect data and process the data, allowing students to analyze, manipulate variables, test hypotheses, and explore relationships (Kelly & Crawford, 1996; Rogers, 1995; Thornton, 1987; Tinker, 1981).

A number of researchers indicated that laboratory equipment plays a major role of providing high school learners with opportunities to develop learning skills in inquiry-type laboratories (Krajcik, Mamlok & Hug, 2001; Hofstein et al., 2005). Stoffels (2005) defines Inquiry-type laboratories as laboratories that have the potential to develop students' abilities and skills such as posing scientifically oriented questions, forming hypotheses, designing and conducting scientific investigations, formulating and revising scientific explanations, and communicating so as to defend scientific arguments. Through scientific inquiry learners are provided with opportunities to learn in a reliable environment and are able to construct their knowledge and cognitive skills are thereby attained.

Learners in under-resourced schools find it difficult to do practical work and rather study them theoretically for continuous assessment purposes as per departmental requirements. There is an urgent need for the engagement of learners in science laboratory activities (Hofstein & Lunnetta, 2004). Lunetta et al (2007) indicated that in rural schools there is a problem as far as Physical Science teaching and learning is concerned

because in the majority of the schools there are no resources. If the school is under-resourced the teacher will use the telling method only and the practical work will be conducted theoretically. In the resourced school learners do practical work, the educator moves around them so as to give assistance where possible using the scaffolding method as noted by Vygotsky (1978). In the scaffolding method an educator gradually decreases his assistance until the learner works independently.

Learners tend to prefer a laboratory learning environment where they have more cooperation. As learners do practical work themselves, they become motivated and interested (Abraham & Millar, 2008). They are supported by Cerini, Murray & Reis (2003) who conducted a survey and discovered that students are more active when they do hands-on practical work. 'Hands-on practical work' is one of the teaching strategies which is a central part of science education (Lunetta & Tamir, 1979). Meaningful learning will occur when learners are able to identify and handle the material to be used. The learners can work so as to achieve the aims and objectives of laboratory activities (Tsai, 2003). In the research conducted by Hofstein & Lunetta (2004) it was found that laboratory activities are very important in the teaching and learning of Physical Sciences. As a science educator I agree with that, because there are so many benefits gained from engaging learners in science laboratory activities. Some of the benefits are as follows: learners conduct more open-ended inquiry, explore more deeply into the connections between theory and practical evidence, and use all their senses to observe the outcomes of the experiment and draw the conclusions themselves and thereby become problem solvers.

There are many programmes of twinning of schools so that the schools can share science equipment. The programmes are aimed at developing higher order thinking skills and skills for doing scientific investigations to encourage children to think about their own thinking (metacognition) and to reflect upon and share their learning experiences (Got & Duggan, 2007). The Cognitive Acceleration through Science Education (CASE), is an intervention programme that aims at improving pupils' reasoning ability by promoting the

development of metacognition. This project was initiated in Malawi (Mbanjo, 2004). The results of the project showed that the programme resulted in improved reasoning ability and school performance.

Perkins (1993) indicated that in most scientific teaching situations, learners should do practical activities so that they can answer the questions that are based on application of the knowledge gained in the laboratory. Perkins further outlined that the advantage of doing practical work is that learners are able to collect the data through the use of their senses. Qhobela et al (2011) suggested that the approach that was used traditionally, where the teacher was regarded as the only source of information, must be replaced with a learner-centred approach. The learner-centred approach is the approach where learners are actively involved and have a high ability to construct meaning about the knowledge. The learner-centred approach encourages learners to investigate, collect the data and draw conclusions themselves.

For an enquiry to Ohm's law, the data collected by the learners will be based on what they see in order to draw up the table and the graph that shows the relationship between current and potential difference. In a test, learners will be able to answer both questions that need higher order and lower order thinking as mentioned by Bloom's taxonomy, and their performance can improve. Learners who are not able to work practically will listen to the information given by educator using the circuit diagram but could find it difficult to apply the information gained to other situations. Information will be memorized rather than applied.

By manipulating Ohm's law apparatus the learners are using knowledge gained through the senses to advance to a higher formal operational level according to Piaget's theory (Wellington & Ireson, 2008). Colburn & Clough (1997) concur by saying that when the experiment is conducted, the steps for experiment are followed so that the learner can understand the concept. These steps are as follows: Aim of the experiment, list of

apparatus used, safety precautions, method for conducting the experiment, collecting and recording of data, data analysis, interpretation and drawing a conclusion.

Abrahams & Millar (2008) identified two domains of knowledge in practical work. The domains are the ones of 'observable' things (things that can be seen) and the domain of ideas. Abrahams & Millar (2008) defined the domain of observable things as those materials that can be seen and given to the learners by the educator. These materials are the materials that can be used by the learners to collect the data based on the topic that is being investigated. The domain of ideas is all the information that is gained by the learners from their educator and through their observations when they do experiments. The learners think about what they have observed and construct meaning so that learning can take place.

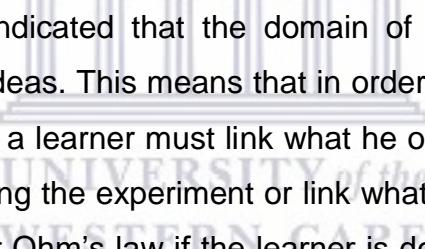

Abrahams & Millar (2008) indicated that the domain of observable things must be connected to the domain of ideas. This means that in order for teaching and learning to be effective in the laboratory, a learner must link what he or she already knows to what he or she observes when doing the experiment or link what he or she observes to what he or she already knows. For Ohm's law if the learner is doing practical work using the apparatus, he or she can be in a position to link what he or she already knows about the law (the statement of the law) to what he or she observes when doing the experiment using all the relevant information. In the case of an under-resourced school, the learners are at least able to link what they already know (names of apparatus) to the pictures and diagrams in the circuit diagram.

## **2.6 Conclusion**

The literature revealed the role played by resources in the teaching and learning of Physical Sciences. The theoretical framework that under-pinned the study was highlighted and discussed. The theoretical framework helps in understanding the

processes that take place in the teaching and learning situation. The conceptual framework of teaching and learning of Ohm's law in Physical Sciences in resourced and under-resourced schools was developed. In the conceptual framework some of the concepts and key words were highlighted and discussed. The studies that are related to the concept of Ohm's law and the research topic were consulted.

The next chapter focuses on methodology. The chapter consists of the research design which indicates the approaches and the instruments that were used for data collection. The population site selection and sampling are explained, as are the data collection method and the tools which were used to analyze the data. Validity, reliability, ethical considerations and limitations of the study are highlighted.



UNIVERSITY *of the*  
WESTERN CAPE

## **CHAPTER 3**

### **RESEARCH METHODOLOGY**

#### **3.1 Introduction**

The previous chapter provided the theoretical framework that underpinned this study. This chapter will provide the methods and instruments used to collect the data. This chapter outlines the research design and provides motivation for the various methodology and instruments used.

#### **3.2 Research design**

A qualitative approach was used in the data collection process. Hoepfl (1997) describes the qualitative approach as the interpretation of the meaning experienced by certain individuals. Furthermore Mouton & Marais (1994) state that the approach helps in obtaining a large amount of information based on a certain study. In a qualitative approach variables are not controlled, instead they are explained using the data collected (Babbie & Mouton, 2001). They further indicate that in a qualitative approach the strength lies in the validity of the study and the findings cannot be generalized. An example of a qualitative approach in the study were the interviews that were conducted because the data was collected verbally.

##### **3.2.1 The advantages of a qualitative approach**

The complete and detailed descriptions of events are provided and the results obtained are accurate.

##### **3.2.2 The disadvantages of qualitative approach**

The data are collected from a few individuals and the approach is time consuming.

#### **3.3 The case study**

This research uses a case study approach. Creswell (2009) defines a case study as a detailed in-depth way of examining a subject of study. A case study is the understanding

of a particular event that is researched in its natural situation which is confined by space and time. Harrison (2002) describes a case study as the strategy which is used to address the understanding of a phenomenon within its functioning context. Mateu (2014) describes his study as a case study of a formal schooling educational setting and it concurs with that of the researcher's study because it is conducted in schools. According to Yin (1993), there are different types of case studies. These are: exploratory, explanatory and descriptive. The exploratory case study is the one that explores any phenomenon in the data which serves as a point of interest to the researcher. The explanatory case study examines the data closely both at a surface and a deeper level in order to explain the phenomena in the data. The descriptive case study describes the natural phenomena which occur within the data in question. The explanatory case study may be used for casual investigations. In this research the explanatory case study was used to compare learner performance in resourced and under-resourced schools. This study also employed a descriptive case study approach as it described the teaching of Ohm's law in its natural environment, namely, in one resourced and one under-resourced school. The data collected reflected what was happening in each school setting and described the interactions in the cases (School A and B) under investigation.

### **3.4 Pilot study**

Porta (2008) defines a pilot study as a minimal test of the approaches and procedures to be used on a bigger scale. The pilot study has a purpose of checking the validity of an approach that is intended to be used in a larger scale study. Bryman (2008) indicates that pilot studies have to be conducted to check whether the instruments serve their purpose. There were many aspects that need to be considered by the researcher when she did the piloting of instruments. The instruments were first given to the researcher's supervisor so as to examine whether they made sense. This means that expert validation was done. For the test and interviews the researcher checked the time taken by the participants to complete answering. According to Johnson & Turner (2000) this would help the researcher to decide whether the instruments are too long or not. The interview schedule was first given to educators who were non-participants in the Grade 10 classes from two

other schools. The reason for piloting the instruments was to check whether the interview questions and test questions were clear and easily understood.

After the interviews the researcher asked the participants to indicate whether there was any important information that was left out and whether the questions were clear or not. The researcher also invited suggestions for improvement and allowed the participants to make some comments. When looking at the responses of the participants, the researcher checked whether the participants understood the questions and whether there were any questions that needed to be rephrased. For questions that showed ambiguity, the researcher decided to rephrase the questions in a simpler and a more straight forward manner. During interviews, the researcher decided to change some of the questions because the participants needed clarity. The test was given to Grade 10 learners of other schools who were non-participants. The test was marked by an educator from the other school. The educator was given permission to do moderation, make comments and make suggestions for improvement.

### **3.5 Sampling**

Sampling is a process whereby people are collected as respondents to participate in a given research (Frankfort-Nachmias & Leon-Guerrero, 1997). Mertler and Charles (2005) concur with Frankfort-Nachmias and Leon –Guerrero (1997) but added that the selected group of people or objects represents a large population. Frankfort and Leon (1997) definition is exactly in line with that of Mkonto (2010). The sample and the sampling technique is summarized in Table 4.

Purposive sampling was used in this study. Purposive sampling is the type of sampling whereby the researcher indicates the characteristics of the population of interest and the individuals are allocated according to those characteristics. All the learners were those studying Physical Science in the same Grade. The sample of two schools for this study was purposively selected from an education district in the Eastern Cape that has a total of thirty-eight secondary schools. One of the schools was a resourced Dinaledi school and the other one is under-resourced.

**Table 4: Sample and the sampling techniques**

<b>Participants</b>	<b>Sample</b>	<b>Techniques</b>	<b>Criteria</b>
Grade 10 learners from both schools were taught by their educators	<u>Resourced school</u> 60 of 154 learners from school A (1 out of 3 classes doing Physical Sciences)	Purposive	Grade 10 learners from the resourced school. All were doing Physical Sciences.
	<u>Under-resourced school</u> 40 learners from school B with only 1 Grade 10 class(whole class)	Whole sample	Grade ten learners from the under-resourced school, all were doing Physical Sciences.
Grade 10 educators	1 educator from school A	Purposive	The Physical Sciences educator of each of the selected classes
	1 educator from school B	Purposive	

The resourced school consisted of three Grade 10 classes studying Physical Sciences. One class of sixty learners consisting of thirty five girls and twenty five boys were purposively selected because of the number of learners available in this class. The total population of Grade 10 learners studying Physical Sciences in the resourced school was one hundred and fifty four. All forty Grade 10 learners studying Physical Sciences were selected from the under-resourced school which consisted of only one Physical Sciences class. The class consisted of thirty girls and 10 boys. Learners from the resourced school were taught Ohm's law practically and learners from under-resourced school were taught theoretically.

The selected educators who were interviewed had 5 years' teaching experience in the grade 10 class and each held a teachers' diploma as a minimum qualification.

### **3.6 Data collection**

Akinyeye (2012) defines data collection as a way of collecting information that is related to a certain study through various methods and sources. Akinyeye's definition of data collection concurs with that of Mkonto (2012). This is in line with my study because observations and interviews were used.

#### **3.6.1 Data collection plan**

##### **Step 1**

Sixty Grade 10 learners from a Dinaledi School (School A) were taught by their educator using the Ohm's law apparatus. The researcher observed the learners using naturalistic observation. Johnson and Christensen (2012) define naturalistic observation as, 'an observation done in a real world setting'. The researcher, the educator and the learners were all in the same laboratory. An Observation checklist was used as an instrument.

##### **Step 2**

Forty Grade 10 learners from the under- resourced school (School B) were taught Ohm's law topic b theoretically by their educator. The same observation checklist was used for both schools by the researcher.

##### **Step 3**

Learners from both schools (school A and school B) wrote the same test for a total of forty based on Ohm's law. Their answer sheets were marked by their educators using a memorandum and the scores were compared and presented in the form of tables and graphs. The results analysis was completed using this information.

##### **Step 4**

Two grade 10 educators (one from school A and one from school B) were interviewed using the same interview schedule.

The data collection is summarized in the methodological framework represented by Table 5.

**Table 5: Methodological framework**

<b>Research question</b>	<b>Sample</b>	<b>Method</b>	<b>Instrument</b>	<b>Respondents</b>	<b>Analysis</b>
How do the teaching and learning of Ohm's law in Physical Sciences compare in resourced and under-resourced schools?					
STEP 1	School A: resourced school	Learners were taught using resources – observed and videotaped.	Observation checklist	60 Grade 10 learners	Video and audio taping Scanning the data
STEP 2	School B: under-resourced school	Learners were taught without resources- observed and videotaped.	Observation checklist	40 Grade 10 learners	Video and audio taping Scanning the data
STEP 3	School A and B	Test and Marking at both schools	Question paper and memorandum	Grade 10 learners from both schools. Subject educators	Scores analysis on recording sheet of both schools
STEP 4		Interview	Interview schedule	One physical science educator from each school	Video and audio taping. Coding

### **3.6.2 Data collection methods**

#### **(a) Observations**

Observation is a data collection method where people or objects are observed when participating in a certain event so as to obtain information about the event. Observation is a method of collecting data using the senses (Fox, 1998). Freebody (2003) added by defining observation as a way whereby people participate in a research and are aware of what they are doing.

In this study, observation was undertaken using an observation schedule and observation checklist (appendix A) which consisted of fifteen themes. The themes were categorized into those that dealt with content knowledge and those that dealt with learner assessment,

with a column for general comments. The themes were kept brief and short so that they could be understood easily. Johannes (2005) affirmed that when observations are done the researcher must be observant at all times when recording observations and the recordings should be made at the time or soon thereafter. Akinyeye (2012) indicated that when the observations are done a researcher obtained a large amount of information from the participants which is not covered in the interview and which provided first-hand information. When the researcher was in the classroom and in the laboratory, observing educators and learners, she was able to observe the collaboration between the educators and their learners.

### **Advantages of observations**

The observations can be made of a large number of participants anywhere but accurate notes need to be taken immediately. The researcher should be able to record the actual behavior of the participants during his or her observation.

### **Disadvantages of observations**

The disadvantage of observation in this study is that the behavior of learners and educators could change especially if they were not accustomed to being observed.

Yin (1994) highlighted that the strong point of observations is that the proceedings take place in actual time but their weakness is that they are time consuming.

### **(b) Test after the lesson implementation**

The test conducted was a formal assessment method used to check whether the objectives of the lesson had been achieved. After the learners from both schools had been taught by their educators and observed by the researcher as participant observer, they wrote the same test which was based on Ohm's law (Appendix C). The test had a total of 40 marks and it consisted of questions that covered lower order, middle order and higher order thinking skills.

The tests for both schools were marked by the educators using a memorandum (Appendix D) and the scores of the learners in each question were compared using the score sheet. Their performance was compared based on the number of correct answers which was in a form of question by question analysis using quantification of the results. The number of correct answers was counted in each question and added so as to obtain the average. The data were quantified.

### **(c) Interviews**

Interviews are used to collect data that is not easy to be observed (Marshall & Rossman 1999; Britten, 1995). Kvale (1996) further defines interviews as data collection methods from individuals through conversations. Babbie and Mouton (2010) indicate that interviews are used frequently to gather information. According to Johnson and Christensen (2004) the interviews are divided into qualitative and quantitative interviews. They further define the qualitative interview as an interview that is written by a researcher and read by the interviewer to the interviewees. As compared to the qualitative interviews, quantitative interviews consist of questions that are open-ended and the data that is provided is qualified. The interviews enable the participants to express their views using their own words.

In this study, the educators who taught each of the sample classes were interviewed after the lessons. Interview questions were based on the qualifications and the experience of the educators, the availability and the use of Physical Sciences equipment when teaching, and the impact of practical activities on the teaching and learning of Physical Sciences. One-on-one semi-structured subject teacher interviews conducted were used to add value to the test results. Mkonto (2010) defines semi-structured interviews as those interviews that combine both structured and unstructured interviews.

The interview schedule (Appendix E) which was used had sixteen questions with both closed questions and open-ended questions which were categorized according to themes. In both schools, interviews were conducted after teaching hours in the library in a friendly environment. Interviews consisted of central questions that defined areas to be

discovered. The interviewer and interviewee were allowed to deviate so that the outline allowed for more detailed responses. .

### **Advantages of the interviews**

Interviews allow the interchange of ideas between the researcher and the interviewee based on the information gathering for the research study (Rossouw, 2005). The interviewer has the ability to listen carefully to the interviewee and use probes and prompts to reach a deep clarity and understanding of what he or she needs from the person who is being interviewed. The interviewer is allowed to change the wording of the question in the interview schedule during the interviews. An interviewer is allowed to ask a follow-up question. Mkonto (2010) indicates that in a semi-structured interview a large amount of data can be collected within a short space of time. Interviews have an advantage of providing convincing substantiation for data presentation when conclusions are made (Koshy, 2010).



### **Disadvantages of the interviews**

The big challenge for interviews is that if they are scheduled during a busy time there is a high possibility of them not being conducted at a scheduled time. The disadvantage of semi-structured interviews is that if the questions are not well-structured the participant can have difficulty in providing meaningful or accurate answers. Consequently, this study asked brief and simple questions, easily understood by the participants.

## **3.7 Data analysis**

Data analysis is defined as the interpretation and the understanding of data that are raw so as to address the aims and provide relevant answers to the research question (Henning, van Rensberg & Smit, 2004).

### **(a) Observations**

The lessons conducted in both schools were videotaped. The observation comments were read repeatedly and themes were noted. The data were scanned, put into themes and was categorized.

### **(b) Test**

The tests for both schools were marked by the educators using a memorandum and the marks were entered in the recording sheet. The scores of the learners in each question were compared using the score sheet. Their performance was compared based on the number of correct answers in the table scores which was in a form of question by question analysis using further the quantification of results. The number of correct answers was counted in each question, and the data were quantified. The observation checklist and the interview schedule were used to ensure validity. The two instruments were relevant; the results were analyzed according to the number of learners providing correct and incorrect answers in each question for both schools. In the table (Table 10) for the results analysis, the resourced school was coded SA, learners from the school LA (Table 8). The sixty learners ranged from LA1 to LA60. The under-resourced school was coded SB: LB for learners and the forty learners ranged from LB1 to LB40.

### **(c) Interviews**

The interviews were video-taped and audio-taped to ensure validity. The data were transcribed, that is, converted from audio to a written form to look for similarities and differences in answers given by the educators. Balgopal (2014) indicated that it is important for interview data to be transcribed. The data were scanned through and written down. The data were cleaned and translated. The researcher read the transcribed interview data many times and colour-coded them for themes that emanated from the interviews.

## **3.8 Coding**

The data collected face to face from the two educators of different schools were coded. The educator from the resourced school was coded as EA1 and the code for the school

was SA. The educator for under-resourced school was coded as EB1 and the school as SB. Learners from school A were coded as LA and listed from one to sixty (LA1 to LA60). The learners from the under-resourced school were coded as LB, starting from LB1 to LB40. For the observation schedule the themes were coded as lines (LN), from LN1 to LN15. The questions from the interview schedule were marked with bullets and coded as BL, from BL1 to BL15. Some of the codes were as follows:

Educator from school A was coded EA1, SA.

Educator from school B was coded EB2, SB.

First learner from school A was coded LA1, SA.

First learner from school B was coded LB1, SB.

### **3.9 Validity**

Validity is a word that deals with the meaningfulness of research components. Content validity is whereby the domain of the concept is made clear and the analyst judges whether the measures fully represent the domain (Bollen, 1989). Triangulation was also used to check whether what is said by the educator was reflected in the learner performance in the test. Triangulation ensures validity. The important aspect of the qualitative research is that the data must be reliable (Lincoln & Guba, 1985). Interview schedules and questions for the test were first given to educators and researchers to check whether they were focused, clear and aligned. The instruments were given to an expert for validation.

### **3.10 Reliability**

Reliability is the degree of stability and accuracy of the results produced by the instrument (Joppe, 2000). Strauss & Corbin (1990) also support this definition of reliability. The interview schedule was first given to non-participants in the Grade 10 classes from two other schools. The reason for piloting the instruments was to check whether the interview questions and test questions were clear and easily understood.

To ensure reliability the instruments were piloted. This means that the instruments were used in the two other schools and given to other educators to check whether the

instruments would provide similar results. Learners from both schools wrote the same test and these were marked by their educators. All the scripts of the learners in the pilot study were sent to the external Physical Sciences educator for moderation.

### **3.11 Research ethics**

To ensure quality and integrity of the research project, the researcher asked permission to conduct this study from all the participants (parents, learners, educators, school principals and the Department of Education officials) and confidentiality of the collected data was ensured (Cohen & Manion, 1994). The respondents were to be anonymous. Permission letters and consent letters were sent to all the participants, parents (Appendix K), learners, educators (Appendix I), school principals (appendix H) and the Department of Education officials. The consent forms were signed by the participants. The researcher applied for the ethics clearance letter from the University of the Western Cape (Appendix G). All the participants were made aware of the fact that if they did not want to take part in the research, they were free to withdraw from participating as participation was voluntary. All the participants knew exactly what they were being asked to do before taking part.

The information sheet concerning the research was used to inform potential participants about the study. All the information regarding the storage of the information and times of lessons, interviews and tests were made known to all participants. Respondents' diversity and inclusivity were taken into consideration. The researcher ensured that there was no favoritism and all the participants were treated equally. Human rights were not violated and the researcher ensured that the participants' rights and welfare were protected. The researcher tried by all means to be friendly at all times during the observation.

Procedures for the research were clearly stated to the respondents beforehand. The researcher applied for the ethics clearance letter to the University of the Western Cape and the clearance form from the Eastern Cape Department of Education to do the research and letters were attached. A letter was sent to the University of the Western Cape Ethics Committee, requesting permission to conduct the research. All the data

collected were made available to participants for accuracy and this is in line with ethical considerations.

### **3.12 Conclusion**

All the aspects of the methodology employed were highlighted in this chapter. A Qualitative approach and instruments were indicated and the justifications were given. Ethical considerations were upheld during the data collection. Data analysis was explained and the findings for this chapter will be presented in Chapter 4.



UNIVERSITY *of the*  
WESTERN CAPE

# CHAPTER 4

## FINDINGS

### 4.1 Introduction

The previous chapter outlined the methodology which dealt with the research design, pilot study, sampling, data collection plan, methodological framework and approach. The instruments that were used to collect the data were test question papers, memorandum, observation checklist and interview schedule. This chapter will deal with the findings from the data collected, following the procedure that was written in the methodological framework in Chapter 3. The chapter is organized around the collected data so as to answer the research question:

**How do the teaching and learning of Ohm's Law in Physical Sciences compare in resourced and under-resourced schools?**

The structure of this chapter is as follows:

- 4.1 Introduction
- 4.2 Classroom observation for the teaching of Ohm's law in a resourced school
- 4.3 Classroom observation for the teaching of Ohm's law in an under-resourced school
- 4.4 The assessment of learners' achievement in a resourced school.
- 4.5 The assessment of learners' achievement in under-resourced schools
- 4.6 Teachers' perceptions of teaching Ohm's law for resourced and under-resourced schools
- 4.7 Summary
- 4.8 Educator's perceptions of teaching Ohm's law
- 4.9 Conclusion

### 4.2 Classroom observation for the teaching of Ohm's law in a resourced school: Example of one lesson observed in the resourced school

The same observation schedule was used to observe the two educators from the resourced school (SA) and the under-resourced school (SB). The observation schedule

consisted of fifteen themes that were coded as lines, starting from line number one up to line number fifteen (LN1 to LN15).

The purpose of the classroom observations was to observe:

- Whether the outcomes of the lesson were clearly stated.
- How the lesson was introduced in both resourced and the under-resourced schools.
- Whether the resources for Ohm's law were available and effectively used.
- Whether the learners were guided in how to use the resources, do experiments themselves and allowed to construct their own knowledge.
- At the approaches that were used by the educators when teaching the learners and how they involved their learners in their lessons.
- The learners' interaction with each other and with their educators during the lesson.
- How the educators' lessons were structured and to look at the assessment techniques that were used by the educators.

The venue that was used by the educator was a Grade 10 classroom. The educator from the resourced school (SA) divided the sixty learners into 6 groups (group 1 to group 6) and in each group there were 9 learners and 1 group leader. The classroom was arranged in such a way that there were 6 work stations and they were labelled as work station 1 to 6. The learners in each group were labelled from learner 1 to learner 10 as explained in the methodology chapter 3.8 (LA1 to LA10). The learners from the resourced school were taught Ohm's law with the use of apparatus.

The researcher was sitting at the back of the class in such a way that she could be in a position to observe and video-tape everything that was happening in the class without any disturbance. Firstly, the educator was assisted by the group leaders from the different groups in collecting the Ohm's law apparatus. Each group was given an ammeter, a voltmeter, a resistor, a switch, three cells, connecting wires and a circuit board. The observation schedule (appendix A) was used as a tool to observe the educator during the teaching of the lesson. The researcher noted the educator's lesson plan so as to see how

it was organized and looked at the steps that were followed by the educator when teaching his lesson.

**The educator's lesson plan was structured as follows:**

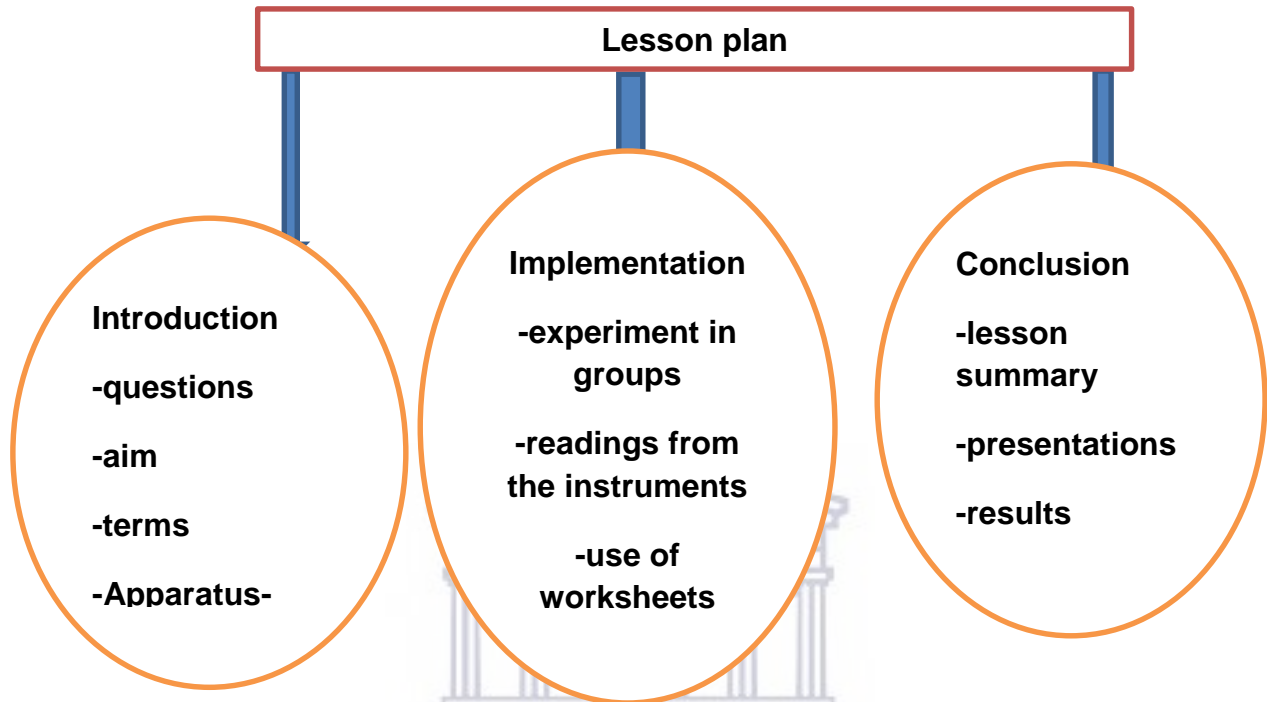

**Diagram 1: The structure of the educator's lesson plan.**

Diagram 1 is the structure of the lesson plan that was used by the educator during his lesson. The introduction of the lesson consisted of questions that were asked, the aim of the experiment, the terms that were found in the Ohm's law topic and the names of the Ohm's law apparatus. In the implementation the learners did the experiment, took the ammeter and the voltmeter readings and answered the questions that were in the worksheet (Appendix B). The conclusion of the lesson was the summary of the whole lesson, the presentations by the learners and the announcements of the results of the learners' presentations.

The educator gave each group a worksheet and explained to them how it was supposed to be used during the course of the lesson. The worksheet was designed to test the learners' understanding of the concepts involved in electricity. Spaces were provided so that learners could explain their answers in detail. The educator introduced the lesson by

asking questions that were based on electric circuits so as to check the learners' prior knowledge and explained the aim and objectives of the experiment.

The educator asked the learners:

*'Who can tell me what electricity is?'*

He received the following responses from the learners:

*Electricity is the current that flows through the wires.* [First learner from the resourced school, LA1]

*Electricity is the flow of charges.* [Second learner from the resourced school, LA2]

The educator asked a follow-up question:

*'What is the SI unit for electric current?'*

The following response was received from the learners:

*The SI unit for current is an ampere.* [LA3]

The educator defined and explained all the concepts that were used in the topic in detail and also wrote them on the board. He listed all the apparatus that were used to conduct the experiment. The terms that were defined were current, potential difference, resistance, resistor, energy, Emf, Ohmic conductor and non-Ohmic conductor, series connection and parallel connection. The apparatus listed were ammeter, voltmeter, resistor, connecting wires. The educator asked the importance of some of the Ohm's law apparatus from the learners and assisted them in answering the questions.

The educator then asked:

*'What is the use of a cell in a circuit?'*

He received the following response from the learners:

*The cell supplies energy to the circuit so that the current can move.* [LA6]

Another question that was asked was:

*'What is the difference between an ammeter and a voltmeter?'*

The responses from the learners were:

*An ammeter is an instrument that is used to measure current.* [LA7]

*A voltmeter is an instrument that is used to measure voltage.* [LA9]

*A voltmeter is an instrument that is used to measure potential difference.*

[LA10]

Other learners' responses to the same question were:

*An ammeter is an instrument that is connected in series* [LA11]

*A voltmeter is always connected in parallel.* [LA12]

In order to check whether the learners had understood the circuit and its connections the educator asked:

*'Why do you put connecting wires in a circuit?'*

Response from the learner:

*Connecting wires join one instrument to another.* [LA10]

The educator further gave the detailed answers to the questions he asked, explained and also wrote the answers on the board. The educator explained how to connect Ohm's law apparatus in a circuit and why they connected in such a way. The educator explained to the learners the reason why the voltmeter is connected in parallel and why the ammeter is connected in series. He showed and explained to the learners how to take the readings from the voltmeter and the ammeter using the different scales that were written in the voltmeter and the ammeter. The educator further identified the 3 variables (dependent, independent and the control variable) that needed to be considered for the experiment.

The learners were given a worksheet and were asked to follow the procedure that was written in it to conduct the experiment in their respective groups. After the learners had connected all the apparatus they were asked to note and write the ammeter and voltmeter readings in the table they were provided in the worksheet. They were asked to connect the second and the third cells in series with the first one. All the learners in all the groups followed the instructions they were given and did the experiment themselves.

The educator moved around the groups, assisting them. One of the questions that was asked by a learner was:

*Why are there no readings on the voltmeter and the ammeter?* [LA4]

The educator went to that group so as to have a close look at their circuit. After he had observed their circuit and identified the problem, he responded:

*The reason is that the switch is not connected properly [EA1]*

A second learner from the same group asked the question:

*Why the voltmeter is always connected in parallel? [LA5]*

The educator responded:

*The reason why the voltmeter is always connected in parallel is that it has a very high resistance. [EA1]*

The learners were asked to draw a graph and write the conclusion which is based on the relationship between potential difference and current using the data from their table and the graph. The educator summarized the lesson by stating Ohm's law, wrote the statement of the law on the board and wrote the mathematical relationship between the potential difference and current. He wrote the equation that shows the relationship between resistance, current and potential difference ( $R = V/I$ ) and showed how the three variables are related.

The educator stated the relationship as follows:

*Resistance is directly proportional to the potential difference and inversely proportional to the current. [EA1]*

*As you increase the resistance in a circuit by connecting more resistors in series the total current in a circuit decreases. [EA1]*

To check whether the learners had understood the relationship between the variables, the educator asked a further question so that the learners could use the formula for Ohm's law.

*If the resistor in a circuit has a resistance of  $4\Omega$  and the current which passes through the circuit is  $2A$ , what will be the potential difference?*

A Learner responded by going to the board and did the calculation:

$$R = V/I$$

$$4 = V/2$$

$$=8V$$

The educator asked the learners to use the set of values they had obtained from the ammeter reading and the voltmeter reading to calculate the resistance. He asked the learners to use the graph they had drawn to calculate the gradient and use the SI units to determine the quantity that was represented by the inverse of the gradient. One of the questions that was asked by the learner from group one (LA1, G1) was:

*Why the ammeter is always connected in series not in parallel?*

Learner number three from group five (LA3, G5) responded:

*The ammeter is an instrument that is used to measure current and has a very low resistance so it must allow more current to pass.*

The learner further continued his explanation by quoting Ohm's law equation as follows:

*According to Ohm's law equation ( $R= V/I$ ) resistance is inversely proportional to the current so if resistance is low current will be high. [L3, G5]*

The educator summarized the lesson and asked one member from each group to give the presentations based on Ohm's law. The educator even showed his learners the tool and a score sheet used to allocate the marks for each group. He encouraged the group members to ask questions to those giving the presentations. The learners asked the questions and the group members assisted each other in answering the questions. After the presentations were completed, the educator announced the results, the groups were so excited that all the groups had achieved above seventy percent. After the educator had finished announcing the results he asked one volunteer from each group to make comments based on the topic. There were no comments. The educator collected all the worksheet from the groups and announced to the learners that they would be writing a test on the work covered the following day.

### 4.3 Classroom observation for the teaching of Ohm's law in an under-resourced school

#### Example of one lesson observed in the under-resourced school

Forty Grade 10 learners, learner one to learner forty (LB1 to LB40) from the under-resourced school (school B) were arranged in 4 rows. In each row there were 10 desks occupied by each learner. The researcher sat at the back of the class in such a way that she could be in a position to observe and video-tape everything that was happening in the classroom without any disturbance. The same observation checklist that was used in a resourced school was used in the under-resourced school. The researcher looked at the educator's lesson plan so as to see how the lesson was structured (introduction, implementation and conclusion).

The structure of the educator's lesson was as follows:

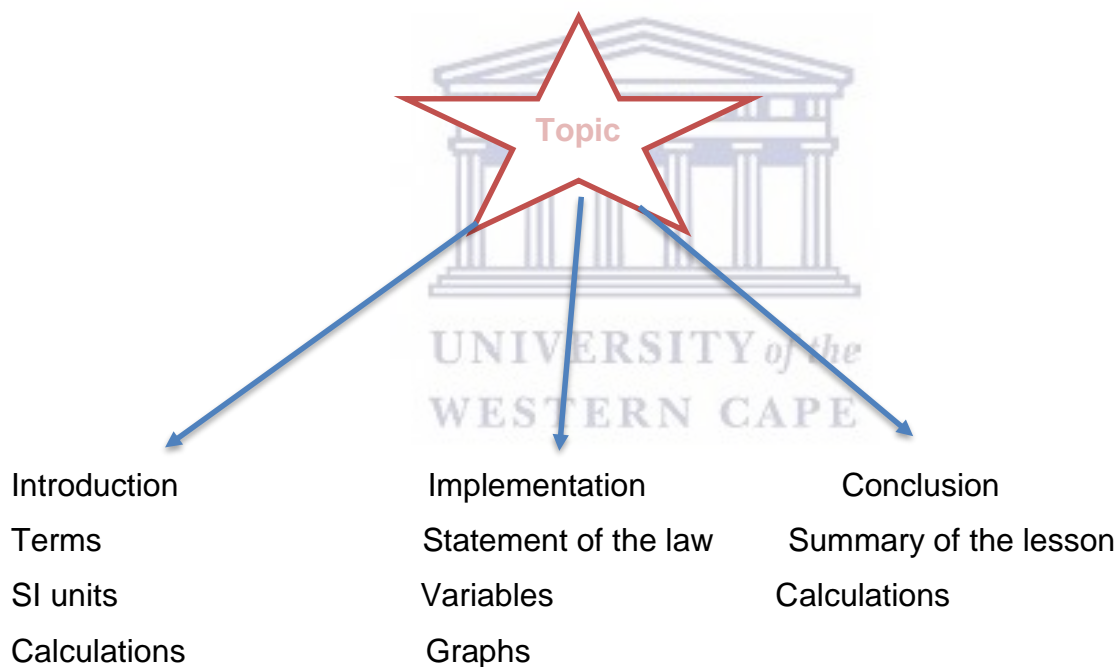

The educator from the under-resourced school (EB1; SB) introduced his lesson by defining all the concepts and quantities that were used in the topic; he also mentioned the SI units for all the quantities. The terms that were defined were current, potential difference, resistance, resistor, ammeter and the voltmeter. He drew two columns on the board and wrote the differences between an Ohmic and a non-Ohmic conductor and gave the examples of each conductor. He stated Ohm's law and wrote all the variables that

needed to be considered for Ohm's law to be valid. The educator explained why the current is a dependent variable and why potential difference is an independent variable.

The educator listed all the apparatus for Ohm's law. He showed the learners how to connect the apparatus for Ohm's law in a circuit diagram that he drew on the board. The educator also wrote the equation  $R=V/I$  on the board and did some calculations. He then drew the table on the board and put in the manipulated values for potential difference and current so as to show the relationship between them. The educator used the manipulated values to draw a graph on the board and he stressed the fact that the independent variable must be put on the x-axis and the dependent variable must be on the y-axis. He also calculated the gradient using the graph and told the learners that the inverse of the gradient of the graph is the resistance.

During the lesson, the educator started a sentence and asked the learners to complete it. Some of the sentences are:

*'Potential difference is an independent.....'*

All the learners concluded the sentence by saying:

*'Variable'.*

*A voltmeter is connected in.....'*

All the learners responded:

*'Parallel'.*

The educator summarized the lesson by giving the learners calculations to be done as class work. The aim of the class work was to check whether the outcomes of the lesson were achieved or not. The corrections for the class work were done on the board by the learners and they were assisted by their educator. The questions that were written on the board were:

*The circuit diagram shows two resistors connected in parallel and one connected in series. The reading on the ammeter is 2A. Each resistor has a resistance of  $2\Omega$ . The potential difference across the terminals of the battery is 6V. Refer to the circuit diagram.*

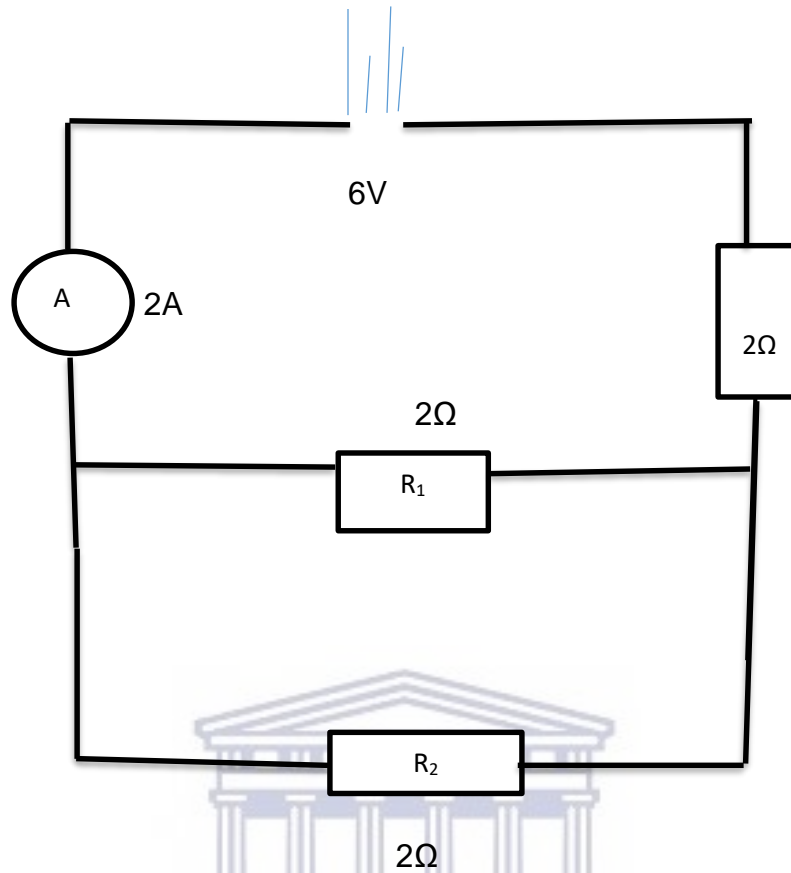

- 1.1 Calculate the total resistance of the circuit. (3)
- 1.2 Calculate the current that passes through  $R_1$ . (2)
- 1.3 Calculate the potential difference across  $R_3$ . (3)

Learners worked out the above problem in their exercise books. Learners were called to the board to write their responses to the questions:

1.1

$$R = V/I$$

$$= 6/2$$

$$= 3\Omega. \text{ [LB1]}$$

1.2 A: Because the two resistors have the same resistance so current will be divided equally. [LB2]

One learner responded by calculating question 1.2 using a different method. His response was:

$$\begin{aligned}1/R &= 1/R_1 + 1/R_2 \\ &= 1/2 + 1/2 \\ &= 1\Omega\end{aligned}$$

$$\begin{aligned}V &= IR \\ &= 2 \times 1 \\ &= 2V\end{aligned}$$

$$\begin{aligned}I &= V/R \\ &= 2/2 \\ &= 1A \quad \text{[LB3]}\end{aligned}$$

Another learner completed the last part of the problem:

$$\begin{aligned}1.3 \quad V &= IR \\ &= 2 \times 2 \\ &= 4V. \quad \text{[LB4]}\end{aligned}$$

The educator informed the learners that they would write a test the following day.

#### 4.4 Outcomes for each of the schools after one lesson on electricity

The educator from the resourced school (SA) clearly stated the outcomes of the lesson and introduced his lesson by defining the terms that were used. The learners from the groups collected the apparatus themselves and were given clear guidelines on how to handle and use the apparatus as they continued the experiment in their respective groups. There was a link between the lesson introduction, the implementation and the conclusion of the lesson. As the educator proceeded with his lesson, the learners had discussions among themselves and exchanged ideas; this means that the learners were allowed to construct their own understanding based on the information and the skills they gained when doing the experiment. The learners from all the groups were allowed to

handle the apparatus and the educator asked some relevant questions. The learners answered the questions individually and there was active involvement of the learners from the beginning of the lesson to the end. As the learners proceeded with the experiment in their respective groups they were allowed to ask questions where possible. The learners were assessed orally, wrote the class work and formally in the form of a test.

The outcomes of the lesson were clearly stated by educator from the under-resourced school (SB); the lesson was introduced through the definitions of the terms and the SI units for the quantities were highlighted. The textbook was used as a reference in listing the apparatus that were used. The educator showed the learners how to draw the circuit diagram.

The learners listened to the educator who answered the questions that were asked by the learners and the approach that was used was teacher-centered. There was no individual answer during the course of the lesson; instead the learners answered the questions as a class. The learners were not actively involved and there was no interaction among the learners. The learners were assessed orally and they were given classwork.

The outcomes of the observations from the lesson presentations were categorized in table 6.

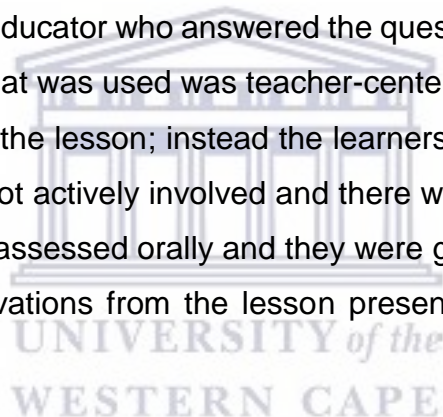

**Table 6: Outcomes of the lesson presentation for the educators from the resourced school and under-resourced school**

Content knowledge.	EA1;SA	EB1;SB
LN1	The outcomes of the lesson were clearly started by the educator.	The educator clearly started the outcomes of the lesson at the beginning of the lesson.
LN2	Lesson was introduced.	Lesson was introduced.
LN3	All the resources to verify the law were available.	Available resources that were used were textbooks.
LN4	Resources were introduced.	Resources were listed.

LN5	Learners were guided on how to handle apparatus.	Learners were shown how to draw the circuit diagram without the apparatus.
LN6	Educator linked the use of the resources with his introduction.	The text books were used as resources.
LN7	Learners were allowed to construct their own understanding.	Learners were just answering the questions that were raised by the educator.
LN8	Learners were allowed to do the experiment themselves in groups; each and every learner was hands-on.	No individual participation during the course of the lesson presentation.
LN9	Learner-centred approach was used.	Teacher-centred approach was used.
LN10	Active involvement of learners as individuals groups and were assisted as they did the practical work.	Telling method, question and answer method.
Content knowledge	EA1;SA	EB1;SB
LN11	The learners participated actively and were encouraged to exchange ideas with confidence and to be creative.	The learners were not actively involved because the educator used the teacher-centred approach.
LN12	Learners were interacting with each other and with the educator through group discussions.	No learners' interaction.
LN13	The educator allowed the learners to ask questions and to explain some of the things that were not clear in the lesson to other learners.	Learners listened to the educator and repeated the definitions of the terms after the educator.
LN14	The educator presented the lesson clearly; the lesson was well structured and he gave the learners clear guidelines on how to use the resources.	The educators presented the lesson clearly using a telling method.
LN15	The educator used a variety of assessment techniques such as oral work, group answers, individual answers and class work that catered for the diverse needs of the learners.	A variety of assessment techniques such as oral work and class work were given to the learners.

#### **4.5 The assessment for the learners from the resourced school**

The following day the researcher observed the educator in the resourced school, arranging the sixty desks in a school hall with his learners in preparation for the test that was based on the Ohm's law topic. The desks were arranged in such a way that the distance between them was half a meter. The sixty learners were arranged alphabetically and each learner was given a question paper, an answer sheet and a graph paper. The subject teacher and two other educators invigilated the learners. One invigilator wrote the start time, the finishing time and the duration of the test on the board. The duration of the test was one hour and the learners started writing the test at 9 am.

The test was out of forty marks and the questions were based on Ohm's law experiment (Appendix C). The test consisted of fifteen questions, starting from 1.1 to 3.11 and they were categorized according to Bloom's taxonomy. There were those questions which belong to the lower order, middle order and higher order thinking skills. The test consisted of 3 groups of questions: question 1 had 2 multiple choice questions, question 2 had 2 one word questions and question 3 had 11 sub-questions. Question 3 was a combination of middle order questions and higher order questions. Questions from question 3 were based on Ohm's law and its application.

The first question required the learners to list the Ohm's law apparatus; the second one required the learners to write the relationship between potential difference and current. The third and fourth questions required the learners to name and state the law they had used to answer the questions. The fifth question required the learners to use the data from the table in drawing a graph. The sixth question needed the mathematical relationship for Ohm's law. The seventh question required the learners to write the procedure that is used to conduct the experiment. The eighth question required the learners to draw the circuit diagram with all the apparatus that are used to conduct Ohm's law. The ninth question was based on the use of the graph to draw the gradient. The tenth and the eleventh question required the learners to apply the Ohm's law in a classroom situation and also in a real life situation outside the classroom.

The memorandum (Appendix D) with all the answers for the test was given to the subject teacher of the school so that he could be in a position to mark the test and write the scores of each learner. The marks were recorded on a recording sheet. The arrangement between the Physical Sciences educator and the researcher was that after 3 weeks the researcher would collect the marked scripts with test records and give them to the Physical Sciences educator who is a Physical Sciences expert from another school for moderation. All the scripts and marks were moderated and the learners' marks were converted to percentages (See Table 7).

**Table 7: Marks and the percentages of the test for the learners from the resourced school**

Learners	Marks /40	%obtained	Learners	Marks	%	Learners	marks	%
LA1	16	40	LA21	25	63	LA41	27	68
LA2	20	50	LA22	25	63	LA42	27	68
LA3	20	50	LA23	26	65	LA43	28	70
LA4	22	55	LA24	26	65	LA44	28	70
LA5	22	55	LA25	27	68	LA45	28	70
LA6	22	55	LA26	27	68	LA46	29	70
LA7	22	55	LA27	27	68	LA47	29	70
LA8	22	55	LA28	27	68	LA48	29	70
LA9	23	58	LA29	27	68	LA49	29	60
LA10	23	58	LA30	27	68	LA50	30	75
LA11	24	60	LA31	27	68	LA51	30	75
LA12	24	60	LA32	27	68	LA52	30	75
LA13	24	60	LA33	27	68	LA53	30	75
LA14	24	60	LA34	27	68	LA54	31	78
LA15	24	60	LA35	27	68	LA55	31	78
LA16	24	60	LA36	27	68	LA56	31	78
LA17	24	60	LA37	27	68	LA57	30	78
LA18	25	63	LA38	27	68	LA58	34	85
LA19	25	63	LA39	27	68	LA59	34	85
LA20	25	63	LA40	27	68	LA60	35	85

Marks were recorded and arranged starting from the lowest to the highest marks. Table 7 shows that in the resourced school three learners obtained marks which were greater or equal to sixteen and less or equal to twenty. Forty six learners obtained marks which were greater or equal to twenty one and less than or equal to thirty and eleven learners obtained marks which were greater or equal to thirty one and less or equal to forty. All the learners passed the test in the resourced school.

#### **4.6 Learner assessment from the under-resourced school**

On the same day the researcher went to the under-resourced school to observe because the agreement was that the same test was to be written by 11 am. The thirty-nine learners were arranged in one classroom alphabetically and the desks were half a meter away from each other. One learner was reported sick, which meant that thirty nine learners wrote the test.

The researcher sat at the back of the class and observed. All the learners were given question papers, answer sheets and graph papers by the two invigilators. The scripts were collected at 12 pm. The educator marked them and recorded the marks. The scripts and the recorded marks for the learners from the under-resourced school were also moderated and the procedure followed was the same as the one that was used for the resourced school. The learner's marks were recorded and appear in Table 8.

**Table 8: Marks and the percentages of the test for the learners from the under-resourced school**

Learners	Marks /40	%	Learners	Marks	%	Learners	Marks/40	%
LB1	8	20	LB14	11	28	LB27	13	
LB2	8	20	LB15	11	28	LB28	14	35
LB3	8	20	LB16	11	28	LB29	14	35
LB4	9	23	LB17	11	28	LB30	15	38
LB5	9	23	LB18	11	28	LB31	15	38
LB6	9	23	LB19	11	28	LB32	15	38
LB7	9	23	LB20	12	30	LB33	16	40
LB8	10	25	LB21	12	30	LB34	16	40
LB9	10	25	LB22	12	30	LB35	16	40
LB10	10	25	LB23	12	30	LB36	17	43
LB11	10	25	LB24	13	33	LB37	18	45
LB12	11	38	LB25	13	33	LB38	18	45
LB13	11	38	LB26	13	33	LB39	19	48

Table 8 shows that in the under-resourced school, eleven learners obtained marks which were greater than eight but less than or equal to 10. Twenty one learners obtained marks which were greater than ten and less than or equal to fifteen. Seven learners obtained marks that were greater than fifteen and less than twenty. The percentage passed and the percentage failed for the learners from the under-resourced school was calculated and presented in the form of a table and pie chart.

**Table 9: Percentage passed and the percentage failed for the learners from the under-resourced school**

Number wrote	% Failed	% Passed
39	49	51

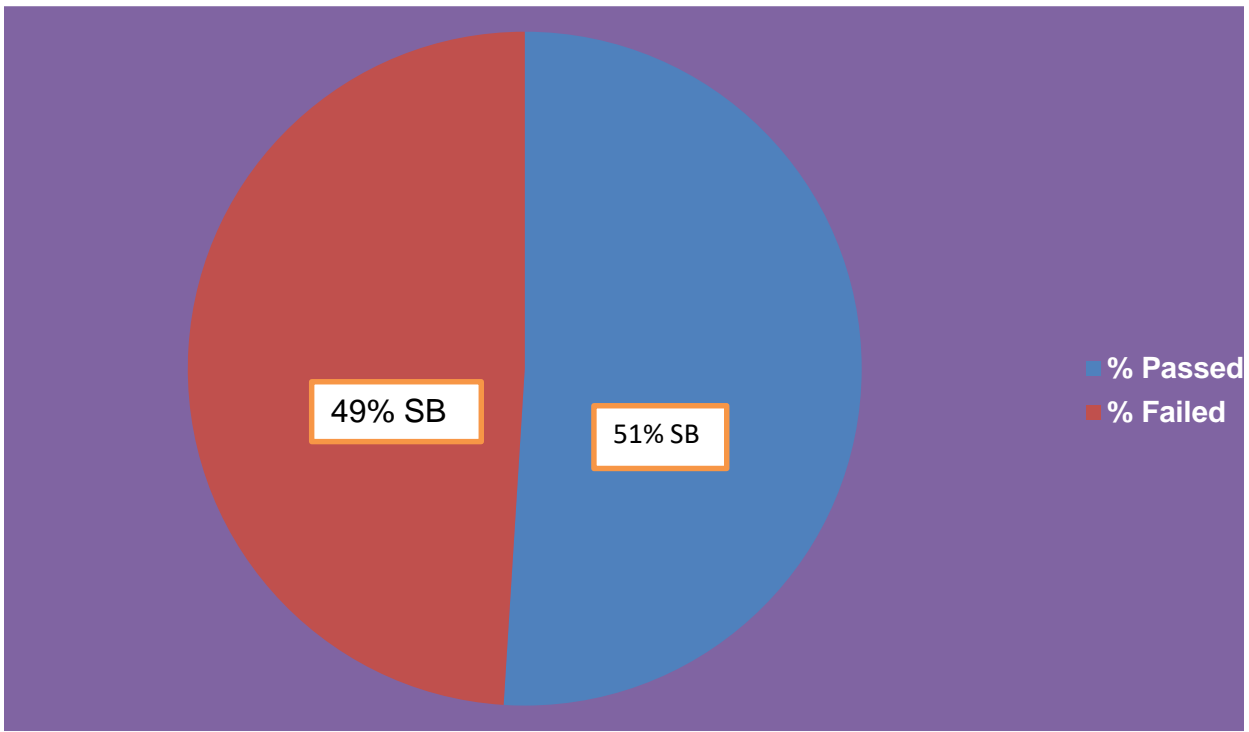

**Figure 2: The pie chart for the percentage of the learners who passed and failed from the under-resourced school**

With reference to Table 9 and figure 2 above it is shown that of 39 learners who wrote the test 51% of them passed the test and 49% failed the test in the under resourced school.

#### 4.7 Comparing test outcomes of the resourced and under-resourced schools

The number of learners from both resourced and the under-resourced schools who provided correct answers in each question was counted and that information was converted to percentages in Table 10.

**TABLE 10: Scores for learner achievement in the two schools**

Test questions	School A: Resourced % of learners who provided correct answers.	School B: under-resourced % of learners who provided correct answers.
1.1	97	62
1.2	78	33
2.1	71	50
2.2	84	46
3.1	93	26
3.2	73	10
3.3	97	69
3.4	81	41
3.5	40	06
3.6	63	44
3.7	30	10
3.8	60	07
3.9	77	01
3.10	87	10
3.11	57	00

A question-by-question analysis of the answers to the questions revealed the following:

##### **Question 1.1: The SI unit for current is.**

In question 1.1 of 100% of the learners who wrote the test, a total of 97% of the learners from the resourced school attained correct answers but only 62% was attained from the under-resourced school in the same question.

**Question 1.2: Which one of the variables is a control variable for the experiment showing the relationship between potential and current?**

78% of the learners from the resourced school answered question 2.1 correctly as compared to 33% of the learners from the under- resourced school. This means that only 22% of the learners from the resourced school provided incorrect answers compared to 77% from the under-resourced school.

**Question 2: Give one word for each of the following phrases:**

**2.1 The rate at which charge flows**

In this question 71% of the learners were correct from the resourced school and 50% of learners were correct from the under-resourced school. This shows that there were more learners from the resourced school who had managed to answer this question compared to those from the under-resourced school.

**Question 2.2: The opposition to the flow of charge**

84% of the learners answered question 2.2 correctly in the resourced school. For the learners who were from the under-resourced school 46% who answered question correctly.

**Question 3: Long questions**

Grade 10 learners from the resourced school set up the apparatus to conduct an experiment that shows the relationship between current and potential difference.

They obtained the following results:

V(v)	I(A)
1. 1.5	2
2. 3	3.5
3. 4.5	5

**Question 3.1: List all the relevant apparatus that are needed to conduct the experiment**

This question was well answered by the learners from the resourced school; the percentage of learners who provided correct answers and listed all the Ohm's law apparatus is 93%. There were few learners from the under-resourced school who were able to list all the apparatus and the percentage was 26%. Of six components of apparatus for Ohm's law some of the learners from both schools mentioned four and others mentioned only two. The mark allocation for this question was 3 marks for 4 components of apparatus, 2 marks for 2 components, 1 mark for 1 component.

**Question 3.2: With the help of the table above write down the noticeable relationship between current and potential difference**

This question required the learners to explain the relationship between current and potential difference using the given table to answer the question. The learners were expected to look at the difference between potential difference and current values. 73% of the learners from School A provided correct answers. In School B only 10% of learners provided correct answers.

**Question 3.3: Name the law which is investigated in the experiment above**

Many learners from the resourced school as well as from the under-resourced school answered this question correctly; 97% of the learners provided the correct answer from SA. 69% from SB provided correct answers.

**Question 3.4: State the law mentioned in 3.3**

81% of the learners from SA answered question 3.4 correctly and 41% from SB answered this question correctly.

**Question 3.5: Graphically represent the information given in the table above by clearly indicating the dependent and independent variables**

40% of the learners from SA answered correctly and only 6% of the learners from SB got the answer correct. In order for the learners to obtain full marks in this question they were supposed to write the heading for the graph, label the axes correctly, mark the correct

points on the graph and provide the correct shape of the graph. The majority of the learners did not use the given points when drawing the graph.

**Question 3.6: What is the mathematical relationship between potential difference and current which is represented by the shape of the graph?**

63% of the learners provided correct answers from SA and 44% of learners from SB provided correct answers. Some of the learners stated the law in words instead of writing it mathematically.

**Question 3.7: In not more than five sentences explain how the learners will use the apparatus in 3.1 when conducting the experiment**

This question required learners to write the procedure that is used to conduct the experiment for Ohm's law and show how all the apparatus were connected. Only 30% of the learners from SA provided correct answers and only 10% of learners from SB provided correct responses.

**Question 3.8: Draw the circuit diagram to show how to connect the mentioned apparatus**

Learners were required to draw a circuit diagram to show how all the apparatus for Ohm's law are connected. 60% of the learners from SA answered correctly, and only 7% from SB gave correct answers.

**Question 3.9: Use the graph drawn in 3.5 to calculate the gradient**

The question required the learners to calculate the gradient using the points that are plotted in the graph. 77% of learners from SA were able to calculate the gradient correctly. Only 1% of the learners from SB provided the correct answer.

**Question 3.10: What does the inverse of the gradient represent?**

87% of the learners from SA provided correct answers and only 10% of the learners from SB provided correct answers. The question required the learners to use the points and the units from the graph to find the answer.

**Question 3.11: What will happen to electricity in a house when you plug more appliances into one socket?**

This question required the learners to apply the information they gained from lesson, based on Ohm's law, to everyday life. 57% of the learners from SA answered this question correctly whereas all learners from SB were unable to answer this question correctly.

The information in Table 10 was converted into a bar graph in Figure 3. The graph was used so that the percentage of learners above and below 50% could be easily shown.

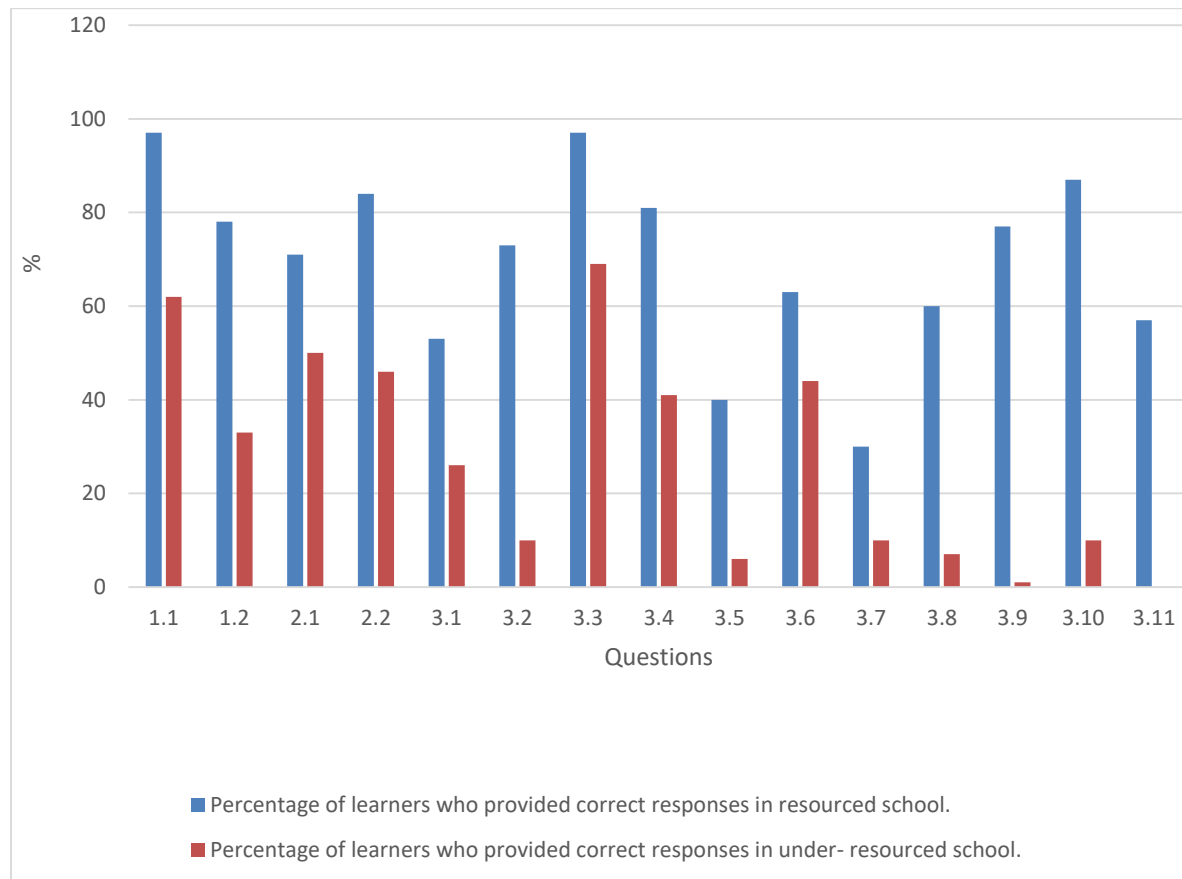

**Figure 3: The percentage of learners who provided correct answers in the resourced school and the under-resourced school**

In the resourced school, SA, thirteen out of fifteen scores were above 50%. The questions where the scores were below 50% were question 3.5 and question 3.7. For the under-resourced school, SB, there were 2 scores which were above 50% and thirteen scores were below 50%. The percentage of the learners who obtained correct answers in

questions that needed higher order thinking in SB is very low as compared to learners from SA. (See. question 3.11).

The results of the learners from both schools were further analyzed according to levels and presented in Table 11 and Figure 4.

**Table 11: Results analysis for the resourced school and under-resourced school learners in terms of levels**

%	0-29	30-39	40-49	50-59	60-69	70-79	80-100	%Passed	% Failed
Levels	1	2	3	4	5	6	7		
SA	0	0	1	11	30	13	5	100	00
SB	19	13	7	0	0	0	0	51	49

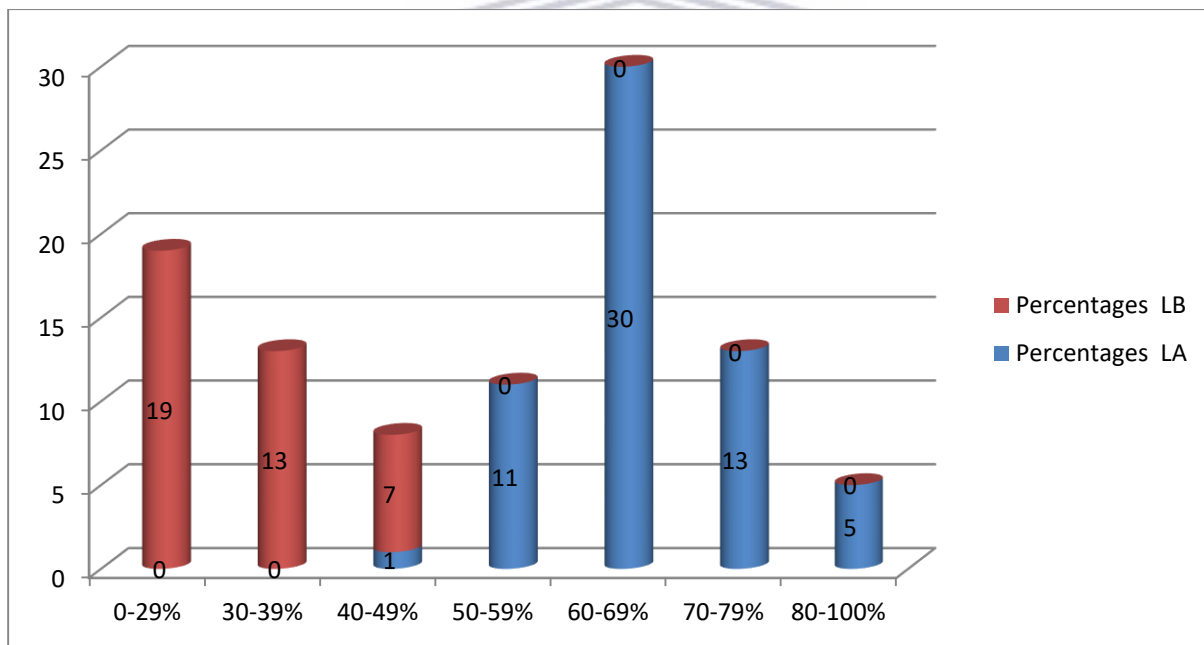

**Figure 4: The number of learners who obtained certain percentages from the SA and SB**

Table 11 and Figure 4 consist of the number of learners who got different percentages in the test and they were also expressed in terms of levels. The levels start from level one to level seven. 0-29% is level 1, 30-39% is level 2, 40-49% is level 3, 50-59% is level 4, 60-69% is level 5, 70-79% is level 6 and 80 -100% is level 7. With reference to Table 11

and Figure 4, there were no learners on levels 1 and 2 from the SA, but there were nineteen learners on level 1 and thirteen on level 2 from SB. Only 1 learner on level 3 was from SA and 7 learners from SB. Eleven learners from SA were on level 4, thirty learners on level 5, thirteen learners on level 6 and 5 learners on level 7. There were no learners who reached level 4 to level 7 in SB. The table further shows that all the learners from the SB were below 50%. Only 1 learner from SA who scored below 50%; all other learners were above 50%.

#### **4.8 Teachers' perceptions of teaching Ohm's law in the resourced and under-resourced schools**

Two educators took part in the interviews which were conducted in two schools. School A, a school with resources and school B, a school which is under-resourced. Educator 1 from school A was coded as EA1 and the educator from school B (under-resourced) was coded as EB1. The educators were interviewed face-to-face, individually, in a school library at both schools. The key themes obtained from the interviews were: (a) Availability of resources

(b) Ability to use resources

(c) Assistance with regard to the use of science equipment

(d) Learner performance.

It was mentioned earlier in chapter three that the interview questions were coded as bullets (BL), from bullet one (BL1) to bullet 15 (BL15).

The first interview question was a closed-ended question and was about the availability of laboratory in the school.

The answer to this question for EA1 was *yes* and for EB1 was *no*.

The second question that was posed by the researcher to the educators was:

*In what ways do you use physical science equipment?*

The interviewed educators expressed themselves through the following quotes:

*With resources the teaching of physical science concepts is effective because most of the concepts in the present syllabus require practical demonstration. Resources*

*enhance teaching and improve the understanding of concepts by the learners and thereby improving learner performance and enable the learners to learn. [EA1]*  
*If I can have science equipment I can use them to do experiments so as to equip my learners with science related skills and also to do the demonstrations. [EB1]*

The researcher continued with the third question:

*How do you rate yourself in doing practical work?*

The answer from EA1 was: *Very confident*. The answer from EB1 was:

*Not confident.*

The educators were asked to give some reasons for their answers to the above question and their responses were:

*My learners master the concepts taught through practical work. [EA1]*

*It is because I do not have science equipment, most of the times I teach my learners theoretically using a teacher-centered approach. I got exposure in my high school days and then at colleges and university days. There is no up to date technological assistance in my school. [EB1]*

The fourth question posed by the researcher to the educators was:

*What assistance do you need in conducting the experiments?*

*More science equipment because now there are more learners who are doing Physical Sciences as it is now no longer a theoretical subject. The learners are doing the experiments themselves and they become more interested in the subject. [EA1]*

*I need provision of Physical Sciences chemicals and apparatus, guidance and some workshops on how to use that equipment. I need training and update in latest effective methods of conducting experiments. [EB1]*

The next question was based on the Physical Sciences equipment, training and the level of effectiveness of the training.

The educators' responses were:

*Yes. It was very effective and modern to such an extent that I had to learn other aspects while teaching. [EA1]*

The response from [EB1] was: No.

This question followed:

*Do you find teaching of Physical Sciences concepts effective? Explain why it is effective and why it is not.*

*Yes. Having equipment makes teaching of Physical Sciences easy and effective. Learners can relate science aspects with their surroundings and use science in everyday life. The effectiveness of it is seen in the learner performance during examinations and the ability to apply the concepts and laws. [EA1]*

*No. Physical Sciences is a practical subject; it needs learners to do a lot of experiments. Due to the absence of science equipment this makes learners to lose interest in the subject and their performance becomes poor in the subject. [EB1]*

A further question asked was: *In what ways does science teacher support material enhance teaching?*

*It equips the educator with various modern day techniques of imparting science in learners. It also makes the learners to understand the information learnt easier and equip them with a number of science related skills. [EA1]*

*It helps the learners to see what they are taught about hence it is easier to understand and recall. Teacher support material makes the teaching of science effective and enjoyable. Students gain confidence and more students can pass the examinations. [EB1]*

The educator from SA also indicated that he has the entire Ohm's law apparatus since his school was supported by the Dinaledi programme and he emphasized the fact that his school is well resourced. He said that he used Physical Sciences equipment in almost

all the topics and sections and his learners are doing exceptionally well because they are participating in hands-on activities which make them perform better. The educator from SB stressed that there is no Physical Sciences equipment in his school and the performance of his learners is very poor in the questions that are based on practical work. The educator from SA expressed himself through the following quote:

*Our school is a Dinaledi school. I was trained in the science equipment usage, gained more skills and self-confidence in handling the apparatus and transfer those skills to my learners, so the performance of my learners is good. Resources enable me to have an effective teaching of Physical Sciences concepts, learners are actively involved in the process of their learning and have better understanding of the concepts. [EA1]*

#### **4.9 Conclusion**

This chapter presented the findings of the research in response to the research question. The findings from this chapter will be discussed in Chapter 5.



## CHAPTER 5

### DISCUSSION

#### 5.1 Introduction

The previous chapter dealt with the findings that were made from the observations of lessons by educators from the resourced and under-resourced schools, the scores of the test that was written by the learners and the educators' interviews. The main purpose of this study is to compare the teaching and learning of Ohm's law in Grade 10 Physical Sciences in the resourced and the under-resourced schools.

This chapter focuses on the discussion of findings from the data that were collected in the previous chapter. The first part discusses and analyses the results from the previous chapter regarding the observations that were made during the teaching of the learners from both schools. Secondly, the results that were obtained from the scores of the achievement written by the learners are also discussed. Finally, the chapter discusses the analysis of the interviews which were conducted with the two educators. The discussions assist in the answering of the main research question:

**How do the teaching and learning of Ohm's law in Physical Sciences compare in resourced and under-resourced schools?**

#### 5.2 Comparisons between teaching of the learners in a resourced school and the teaching in an under-resourced school.

The findings from the observations in Chapter 4 outlined that the educators from the two schools (SA and SB) have used different teaching strategies.

##### 5.2.1. The teaching strategies used in the resourced school.

The educator from SA used the learner-centred approach together with the question and answer method when teaching the learners. The reason why the approach was learner-centred is that during the lesson presentation the educator introduced his lesson by asking the learners a series of questions throughout the lesson, which aroused the learners' curiosity and kept them alert at all times. The open-ended questions encouraged

the learners to analyze, interpret and predict information. The majority of the learners made a connected effort to answer the questions and the educator also gave the learners the chance to ask their own questions. Some of the questions that were asked by the educator were:

(a) *'What is the SI unit for electric current?'*

(b) *'What is the use of a cell in a circuit?'*

(c) *'What is the difference between an ammeter and a voltmeter?'*

The learners' responses were:

*The SI unit for current is an ampere. [LA4]*

*The cell supplies energy to the circuit so that the current can move. [LA6]*

*An ammeter is an instrument that is used to measure current. [LA7]*

*A voltmeter is an instrument that is used to measure voltage. [LA9]*

*A voltmeter is an instrument that is used to measure potential difference. [LA10]*

The learners asked the following questions:

*Why are there no reading on ammeter and voltmeter?*

Educator's response:

*The reason is that the switch is not connected properly [EA1]*

A second learner from the same group asked the question:

*Why the voltmeter is always connected in parallel? [LA5]*

Educator responded:

*The reason why the voltmeter is always connected in parallel is that it has a very high resistance. [EA1]*

The educator's role was to act as a facilitator who provided guidance to the learners on how to proceed with the experiment. The learners were guided by their educator on how to handle the apparatus and did the practical work using the resources. The scaffolding method was used in SA.

Another reason why the approach was learner-centred is that the group members from all the groups were hands-on doing the Ohm's law experiments, feeling and sensing and they were guided by the instructions that were drafted by the educator in the worksheet.

Hampden-Thompson & Bennet (2013); Zimbard, Bugacic, Calthorpe, Goodwill & Lluka (2013) stress that in the laboratory learners interact with hands-on activities. The results from the observation showed that the learners were able to draw the conclusion for the relationship between potential difference and current using the data they had collected. The observation results concur with the study that was conducted by Woolfolk (2007). The learners were able to discover by themselves the relationship between variables through the guidance they received from their educator. Donald, Lazarus, Lolwana & Mkonto (2010) term this approach to teaching and learning as 'guided discovery'. According to Goodwin (2014) when the learners interact with the materials they learn by discovery.

There was an exchange of ideas among the learners and between the educator and the learners from the SA when they did the practical work in groups. The learners discussed the ideas among themselves and they supported each other during the process of teaching and learning. The strategy of grouping learners into small groups in a class gave them the chance to express their ideas even to shy and slow learners. During the process of teaching and learning the learners were given constant assistance by their educator and by other group members. The learners were learning as they were doing the practical work because they were handling the apparatus themselves, observing the relationship between the variables, using the data they collected themselves through to interpretation and analysis of the results.

The topic that was being taught became clearer to the slow learners because the learners were taught at a slow pace and learned at their own pace. This is supported by the study that was conducted by Lowery (1994) and Grennon Brooks & Brooks (1993). The learners become actively involved in the process of their learning and in this case teaching and learning become a two-way process. It is a two-way process because the learners were guided by their educator when they conducted their experiment themselves, with the educator asking pertinent questions and the learners being encouraged to ask their own questions as they worked through the experiment.

When the learners learned on their own using the resources they understood the concept better and tried by all means to find the meaning of what they were doing. The learners

were able to apply the knowledge gained to understand the new concept. They used the collected data to draw the graph for Ohm's law and they were able to apply the information they already had from Mathematics to calculate the gradient. The learners linked the information they gained when they did the practical with the information from the graph they drew (ability to use the graph in calculating the gradient). This supports the idea that the teaching and learning of Physical Sciences involves seeing, handling and manipulating of real objects and materials.

When the learners conducted the experiments using the resources themselves, they found Physical Sciences more enjoyable. This became clear when the learners from different groups were observed presenting their findings for the whole Ohm's law topic without any fear. When learners from different groups asked some questions (LA1, G1) which arose from the presentations, the presenter, together with his or her group members (LA3, G1 and LA3, G5), answered the questions without any hesitation. The learners gave a clear answer which is an indication that they knew what they are talking about and were able to provide further information beyond that which was provided by their educator. It was discovered that learning using the resources enabled the learners to learn on their own and have a better understanding of the concept.

### **5.2.2. The teaching strategies that were used by the educator from the under-resourced school.**

The educator from SB used the teacher-centred approach because there were no resources in the school to conduct the experiment for Ohm's law. As it was already indicated by Lunnetta, Hofstein & Clough (2007) that some schools have no Physical Sciences resources, Physical Sciences is therefore taught theoretically. The reason why the approach used is regarded as teacher-centred is that the educator started his lesson by defining some of the terms, listed the apparatus for the experiment, and drew a circuit diagram on the chalkboard. The manipulated values for the voltmeter readings, the ammeter readings and the relationship between the potential difference and current were also written on the board. He concluded his lesson by writing the statement of Ohm's law on the board.

Most of the lesson had the learners sitting at their desks, listening attentively to their educator who was the only source of information. This style of teaching was observed by Kibirige & Hodi (2013); Qhobela & Moru (2009) and Maquthu (2003). Qhobela & Moru (2009) mention the expression 'chalk and talk' whereby the educator teaches the learners by writing notes on the chalk board without asking any questions from the learners. The teacher-centred approach was apparent since the educator was the only source of information as he was just pouring or depositing the information into the learners. He did not give the learners an opportunity to ask questions. When the educator did ask questions, he assisted them in answering those questions. According to MacDermott (1993) the teacher-centred approach is also called the traditional approach. Listed below are some of the sentences that the educator assisted the learners in completing:

*Potential difference is an independent.....*

All the learners concluded the sentence by saying: *Variable.*

*A voltmeter is connected in.....*

All the learners responded: *Parallel.*

The graph that showed the relationship between electric current and potential difference was drawn by the educator on the chalk board and the educator used the graph to calculate the gradient. The learners were just observing and listening to their educator, took down the notes that were written on the board and answered the questions orally. The learners were passively listening to their educator and they were assessed individually in the form of the classwork given at the end of the lesson.

### **5.2.3. The summary of the lessons**

At the conclusion of the lesson, the learners from SA were able to summarize the lesson following all the steps that were written on the worksheet. In SB the lesson was summarized by the educator and the learners were given classwork. The classwork was composed of questions that required learners to do calculations using the formula for Ohm's law.

Learners from SA were responsible for their own learning. The fact that the learners summarized the lesson themselves showed that the learners had understood the lesson. In SB the learners were the passive recipients who were most of the times listening to their educator. The educator's role during the lesson in a SA was to guide and support the learners in using the apparatus. The classroom observation indicated that when the learners were actively involved in the process of their learning they had a better understanding of the topic.

### **5.3 Comparing the test scores of learners from the resourced and under-resourced schools.**

The marks for the test of all the sixty learners from SA were recorded and presented in Table 7 and the marks for the thirty-nine learners from SB were presented in Table 8. The marks were arranged starting from lowest marks to the highest marks. The number of learners who provided correct answers from both schools was counted and the information was converted to percentages. The scores of learners from SA and SB were compared using Table 9 which shows the percentage passed and percentage failed for learners from both schools. Table 10 and the graph in figure 3 showed the percentage of learners who provided correct answers in SA and SB. Further comparisons were made and were based on number of learners versus levels (Table 11), and the level distribution for each question for the learners from both schools.

#### **5.3.1 Learners from SA out-performed those from SB**

Three learners obtained a percentage which ranged between 0% and 51% in the class that was taught practically and all the learners that were taught theoretically obtained a percentage that ranged between 0% and 51%. The percentage range for 46 learners was between 51% and 75% and for 11 learners the percentage ranged between 78% and 100%. The difference in learner performance is due to the fact that the learners who were taught practically using the resources had a greater opportunity of interacting with the material they used to do the experiment. The learning is activity-based and the learners retained what they had learnt and performed much better than those in SB.

Question 1.1 required the learners to choose the correct option from four given options, there was a difference of 35% in the pass rate of the learners from SA and the learners from SB. The correct answer was C (ampere) but the majority of the learners from both schools chose letter A (volt).

In question 3.4 the percentage of the learners who provided correct answers was higher in SA compared to that of the learners from SB. The percentages were 81% for SA and 41% for SB. This question required the learners to state Ohm's law, the table and the graph indicated that more learners from SA were able to state the law. The learners who were incorrect wrote only the relationship between the potential difference and current but forgot to mention the control variable (temperature). Some of the learners wrote that the potential difference is inversely proportional instead of directly proportional. They did mention the two variables correctly. The answers provided by some of the learners indicated that those learners did not understand the meaning of the law.

Few learners provided the correct answer in question 3.5 from both schools, the poorer results resulting from the learners from SB. The learners were awarded full marks for writing a suitable heading for the graph, correct labels with units on both axes and correct points on the graph. Most of the learners forgot to write the heading for the graph and correct units on both axes. Other learners just drew the straight line graph without plotting any points. The information provided above shows that the learners just understood the meaning of the word directly proportional and were unable to apply the information they were given from the data.

Question 3.6 required the learners to write Ohm's law mathematically. There was a difference of 19% in the performance of the learners. From the answers that were provided by the learners from SB it was noted that the learners did not know the meaning of the expression 'mathematical relationship'. Some of the learners just wrote the law in words. From the procedures written by the learners for question 3.7 it was noted that the learners knew the apparatus to conduct the experiment but they found it difficult to write the procedure required to use the apparatus' components in their correct order.

The difference between the two schools in learner performance in question 3.8 was as large as 53%. The data show that there were many learners from SB who were unable to answer the question. The question required the learners to draw the circuit diagram, some of the learners from SB connected the components incorrectly. Instead of connecting the ammeter in series they simply connected it in parallel and the voltmeter in series.

The last three questions of the test, 3.9;3.10 and 3.11, tested higher order thinking skills and the performance of learners from SA was notably better than that of the learners from SB. Questions 3.9 and 3.10 required application of the knowledge the learners already had in Mathematics to solving problems in Physical Sciences. The learners were required to use the formula of the gradient which is  $m=y_2-y_1/x_2-x_1$  so as to find the inverse of the gradient. Of the learners in SA, 77% provided correct answers in 3.9, 87% in 3.10 and 57% in 3.11. Of the learners from school SB, only 1% provided a correct answer in 3.9, only 10% provided correct answers for 3.10 and no learners from SB provided a correct answer for 3.11. Very few learners were able to choose any two points from the plotted graph and use those points to calculate the gradient. Once the learners from SA had calculated the gradient they were able to note that the inverses of the gradient represented the resistance. The differences in the results from the last three questions was substantial.

The learners from SA seemed to be constructing new knowledge when they answered question 3.11. This question required the learners to link the school knowledge they had gained from their educators with everyday knowledge. By referring to the data collected it has been proved that the learners from SB found it difficult to apply the knowledge they had been taught to solve problems. One learner from SA answered 3.11 by saying, 'As you connect more appliances the resistance will increase leading to the decrease in current and the multi-plug will shut down because according to Ohm's law resistance is inversely proportional to current'. The learners' answers are in line with constructivism theory which was explained in Chapter 3. The learner's answer is an indication that the learner was able to apply the knowledge gained from the classroom to new knowledge.

In almost all the questions, the percentage of learners who provided correct answers was considerably higher in SA as compared to SB.

The Table 10 and the Graph (Figure 3) show that out of 15 questions there were only two percentages which were below 50% from SA. Questions 3.5-40% required the learners to represent the data they had collected from the readings graphically and question 3.7-30% required the learners to write the procedure to follow when conducting the experiment. This does not mean that the learners were unable to answer the whole question but some of the important components of the answers were omitted. Percentages from SB which were below 50% were: 1.2 - 33%, 2.2-46%, 3.1 - 26%, 3.2 - 10%, 3.4 - 41%, 3.5 -6%,3.6-44%,3.7 -10%, 3.8 - 7%, 3.9 - 1%, 3.10 -10% and 3.11 - 0%.

The question by question analysis that was further done to compare the learners' results in every question showed that, in each case there was a better learner performance from SA. More learners from SA attained level seven and few level one compared to those from SB.

The use of resources when teaching learners contributed to the improvement of learners' higher order learning skills such as analyses of data, problem solving and evaluating. The learners' understanding of the concept was improved because the learners got better understanding of scientific concepts through the manipulation of the laboratory resources in order for the Physical Sciences topic to be successfully taught and successfully understood. This is supported by Dhurumraj (2013) who attests that resources need to be available so that the theory taught is able to be put into practice

Singer et al (2005) highlighted that when the learners do practical work themselves using laboratory resources, they are able to understand the subject, their scientific reasoning is developed, and learners are equipped with practical skills. The learners became interested in learning more about science and are able to apply science knowledge to everyday life. When the learners did the experiment in groups they were able to share and discuss the ideas among themselves and were able to assist each other, and by so doing, team work abilities were developed.

There was an exchange of ideas among the learners from SA. The learners were learning by doing because they were handling the apparatus themselves, observing the relationship between potential difference and current. The data were collected by the learners themselves, interpreted and analyzed by them. They demonstrated a high ability to use the collected data when drawing the conclusion. The learners were able to state Ohm's law using the recorded values for voltmeter reading and ammeter reading. When the learners from SA did the practical work themselves using the resources, they found Physical Science more enjoyable, because the teaching and learning of science involves seeing, handling and manipulating real object and materials.

#### **5 4 Educator interviews**

The interviews were conducted with the two educators from SA and SB. The aim of the interviews was to find out what educators thought about teaching and learning in a school using the available resources. The researcher has provided the analyses of the responses to the questions that were asked during the interviews.

The two educators that were interviewed (EA1 and EB1) had a common agreement that the teaching of learners using resources, such as Ohm's law apparatus, equips the educator with various new teaching methods that assist the learners in understanding what is taught more easily. They further highlighted that resources enable the learners to understand the information learnt more easily and equip the learners with a number of science related skills. The educator from SB further highlighted that teaching using the resources helps the learners to see what they had been taught hence it is easier to understand and recall the topic. The teaching of learners using Physical Sciences resources makes the teaching effective and enjoyable, allows students to gain confidence and there is a high possibility that more learners are in a position to pass the examinations.

The educator from SB stated that he did not use the laboratory equipment when teaching Physical Sciences because his level of science equipment usage is very poor and the performance of his learners is also not good in the experiments because the learners do

not perform the experiments themselves. He even pointed out that sometimes the learners just take the manipulated readings from the educator and do the calculation using those readings.

#### **5.4.1 The use of Physical Sciences equipment**

The educators from the two schools agreed that Physical Sciences equipment plays a major role in assisting the learners in performing the experiments in groups or individually. In many instances, the educators give demonstrations if there is a shortage of apparatus.

#### **5.4.2 The assistance that is needed by the educators**

The educator from SA indicated that the science equipment available in his school is not sufficient as there is an increasing number of learners who are doing Physical Sciences every year. The reason for the gradual increase is that the parents and learners were impressed by his good Grade Twelve results. The educator highlighted that in each year there were some learners who attained level 7 in Physical Sciences in his school. He also mentioned the fact that when the learners were doing the experiments themselves they became more interested in the subject. Regarding the question that enquired what assistance was needed, the educator from SA responded that he was in need of more Physical Sciences chemicals and apparatus, guidance and more workshops on how to use the equipment. The educator from SB also mentioned that he does not have the skills to conduct some of the Physical Sciences experiments.

#### **5.4.3 Training in Physical Science equipment usage and its effectiveness**

The educator from SA stated that he received good and effective training on how to use the Physical Sciences equipment. The educator from SB said that he did not receive any training in Physical Sciences equipment usage.

#### **5.4.4 Availability of resources**

The educator from SA stated that in his school there were science resources because they were supported by the Dinaledi programme. He further said that when the learners were doing the experiments themselves they had a high ability of applying the information

they had gained to new concepts and also to solve the problems they have within their society. Even during the examinations, the learners could apply that knowledge when answering questions. The educator from the SB stressed the fact that there were no Physical Sciences resources in his school and it was difficult to teach Physical Sciences concepts.

It was found from the educator's response from SB that the teaching of Physical Sciences concepts is not effective in the absence of resources. The educator highlighted that most of the times he just explained all the steps needed for practical work without doing it and the learners were told to read the procedure from the text book. The learners were unable to conduct Ohm's law experiment without resources and hence were unable to provide correct answers in formal assessments. Most of the time, in under-resourced schools, learners just memorize, without understanding, the information given by their educator.

The educator from SB emphasized that Physical Sciences is a practical subject that needs learners to perform experiments. He added that due to the absence of equipment this makes the learners lose interest in the subject and their performance is poor.

In SA there was an improvement in learners' performance because when they did the experiments themselves their understanding was improved as they were able to interpret what they saw and were able to apply the theory. This study is in line with the study that was done by Tobin (1990) who reported that laboratory activities are an alluring and interesting way to learn with understanding whilst at the same time the learners are engaged in a process of constructing scientific knowledge by hands-on activities.

Once the data analysis had been done, the findings showed that there is a marked difference in the teaching and learning when the learners are taught using the resources. There was a considerable improvement in the way in which the learners answered the questions from SA and the majority of the learners showed a better understanding of the Ohm's law concept. The findings show that the learners from SA performed far better

compared to the learners from SB. The result analysis showed a considerable difference in the quality and quantity of the results.

It was also revealed by the findings of this study that the learners acquired a number of scientific skills when they learn with resources. They formulated the explanations of the scientific phenomenon that were based on evidence and the explanations were communicated to other members of the group. The educator assisted the learners in connecting patterns in the data collection to establish a scientific law. Resources play a major role in making abstract ideas concrete and realistic. When the learners are taught using resources they are exposed to meaningful learning because they observe everything that is happening during the experiment; collecting the apparatus, touch and accurate observations are encouraged.

In order to note the learners' performance, the test scores were compared. The collected data from the observations and test scores were aligned with information that the researcher obtained from the two educators' responses during the interviews. The findings from this study are in line with the study that was conducted by Abrahams and Millar (2008) which emphasized that learners have a higher ability to link what they observed when doing the experiment to what they already know about the concept being investigated. The outcomes of the study indicate an agreement with the study by Grennon Brooks & Brooks (1993,p.56) who pointed out that "the search for understanding motivates students to learn, when students want to know more about an idea, a topic, or an entire discipline, they put more cognitive energy into classroom investigations and discussions and study more on their own".

Constructivism theory indicates that when the learners do the experiment themselves they are able to use their own understanding to find the meaning of what is taught by their educator (Robottom, 2004). It is easy for learners to understand and remember the law, as an English idiom says 'practice makes perfect'. Resourced school learners have greater success because the learners can even put the law into their own words due to their better understanding. This means that deep learning occurs because the learners

think critically about the ideas so as to see relationships between them. Makgato and Mji (2006) assert that learners' higher order thinking skills are improved when the learners do practical work. This is the reason why it is important to teach the learners using concrete materials. In this study, this method of teaching assisted the learners in remembering easily the concept that was taught, whereas in the under-resourced school, most participants performed poorly in the achievement test. This research finding is a result of inadequate concept development leading to the participants' inability to develop higher order thinking skills relating to data analysis and data interpretation.

Laboratory work plays a central role in science because the laboratory environment is totally different from the classroom environment where learners sit down and listen to the educator who is pouring the information to them using the teacher-centered approach. Okanlawon (2012) indicates that if the learner understands the procedure, then it is easier for him or her to remember and reconstruct it when it is asked during formal assessments. He further supports his statement by saying, 'If the school has a laboratory with enough resources, teaching will be effective and the learners will achieve better'.

If the Learners are doing practical investigation and experiments teaching and learning become interesting because learners can take responsibility of their learning. The experiments are there so as to stimulate a learner's curiosity and interest (National Curriculum Statement Policy, 2007). As the learners do experiments in groups they discuss their observation and share ideas among themselves and learning occurs as they interact with each other (Vygotsky, 1978). The findings of this study revealed that there is a marked difference in the teaching and learning when the learners are taught using the resources compared with when they are taught theoretically only.

## **5.5 Conclusion**

The results obtained in the previous chapter showed that in the class of learners where the lesson was taught practically, the learners performed the experiment themselves in groups and were actively involved in the process of their learning. The learners were learning as they were undertaking the practical work. The theory of Ohm's law was put

into practice because they were hands-on in doing the practical. There was a change in the learner understanding. This chapter discussed the findings obtained in Chapter 4 in order to answer the research question. The next chapter will focus on the summary and the conclusions drawn from the study.



UNIVERSITY *of the*  
WESTERN CAPE

## **CHAPTER 6**

### **SUMMARY AND CONCLUSION**

#### **6.1 Introduction**

The previous chapter presented discussions of the findings that were obtained from chapter four. In this chapter, the overview of the study, its major findings and implications of the study take centre stage. Also taken into thorough consideration are the limitations and recommendations for future research.

#### **6.2 Overview of the scope of the thesis**

Chapter 1 focused on the introductory part of the study and delineating the aim of the study. The context of the study gave a brief description of the school at which the researcher was teaching as well as the profile of the two research sites (a resourced and an under-resourced school). Highlighted in the background to the study were the problems facing Physical Sciences Education including poor performance at national, provincial, district and school level. Also attached to cement the vision is a 2014 question by question analysis together with matric results for the past seven years (2010-2016).

The changes undergone by an education system, challenges and problems encountered are all clearly outlined in the State of Science Education in South Africa report. Also included are the intervention and support programmes by the Education Department specifically tailor made to assist both learners and educators in uplifting the standard of Physical Sciences education. The research problem was discussed, a research question was posed, and the significance and limitations of the study were outlined. All the chapters in the thesis topic were listed in the structure of the thesis section.

Chapter 2 focused on the literature review which consisted of the definitions of the terms, the research question, theoretical framework, the conceptual frame work and the conclusion of the chapter. Some of the terms that were used in the research were defined,

while concepts and ideas related to the Ohm's law topic and to the study were discussed. The literature related to this study was reviewed and related international, national and local studies were discussed. The theory (constructivism) that underpins the study was explicated and its major topics were highlighted.

In Chapter 3 the methodology was clearly outlined. The following aspects were dealt with, namely: the research design, the case study approach, the pilot study, the data collection, the data analysis. The coding, validity and reliability, research ethics and the conclusion of the chapter were explicated. A qualitative research design approach adopted to collect the data was discussed. In the discussion of this approach the advantages and the disadvantages were highlighted. The case study approach was also described. A pilot study was embarked on to check the validity and reliability of the approach, including the essence and the usefulness of the instruments that were used to collect the data. The sample, the sampling techniques and the criteria for sampling were discussed and all that information was summarized in Table 4. The reasons behind the choice of the sample of schools, learners and the educators were highlighted. A clear plan used to collect the data was drafted and categorized into steps as follows:

1. Teaching of Ohm's law to Grade 10 learners from the resourced school.
2. Teaching of Ohm's law to Grade 10 learners from the under-resourced school.
3. Writing of the test by the learners from both schools.
4. The interviews of the educators from both schools.

The summary of the data that were collected was presented in the methodological framework table (Table 5). This chapter also discussed the methods used to collect the data which included the observations, test and interviews. The advantages and the disadvantages of observations and interviews were highlighted. The data analysis methods were also mentioned while the codes used in the research were explained. These included the codes for the two research sites, educators, and learners from the two research sites, themes from the observation schedule as well as the questions for the

interview schedule. Finally, the validity, reliability of the research and the research ethics were discussed.

In Chapter 4, findings of the research were clearly outlined in terms of the lessons observed, one in each category, as well as outcomes of each lesson observation, assessment of learners from both schools and comparisons of outcomes from both the resourced and under-resourced schools and educators' perceptions on the teaching and learning of Ohms' law in both resourced and under-resourced schools. The observation schedule was used to observe educators while the test scores were used to compare learner performance from both schools. The data that were collected was presented in tabular and graphical format. The interview schedule was used as an instrument to collect the data from the two interviewed educators.

In Chapter 5, the findings that were obtained from the observations of the lessons implemented by the two educators teaching in both schools were discussed. Also discussed were the scores obtained from the test written in both schools and the findings from both educators who were interviewed.

### **6.3 Major findings of the study**

The findings from this study revealed great differences between the two teaching approaches used by the two educators. The educator from the resourced school used a learner-centred approach while the other educator with no resources opted for the teacher-centred approach or the lecture method.

It was discovered that the educator who used resources could easily adopt a learner-centred approach where learners could grasp the topic on Ohm's law since they were responsible for their own learning. Learners could comfortably go beyond the information given by their educator. A noticeable interest in lessons and positive attitude developed towards the lesson and active participation was a major characteristic feature of the class taught using the resources. Written tests results also attested to this. However, the method is deemed to be a time-consuming one.

In the under-resourced school, the educator was obliged to use a teacher-centred approach which seemed faster and time-effective. However learners did not feel responsible for the work done, and appeared to develop a negative attitude towards lessons since grasping of concepts became difficult.

Both the educators interviewed emphasized that teaching using resources simplified teaching and learning and improved results. The under-resourced school's educator revealed that he found it difficult to impart Physical Sciences theoretically since it was a practical subject that needed learners to be hands-on doing experiments. This was evidenced by the mediocre performance from the tested learners. These learners underperformed in practical related questions.

The educator from the resourced school stressed the need to update his laboratory since most of his resources were being exhausted and a rapid increase in the number of Physical Sciences learners had added more pressure on the resources available. The under-resourced educator highlighted his desperate need for resources and workshops to train him on how to use the resources.

#### **6.4 Implications of the study**

Physical Sciences is a subject that calls for the educators to demonstrate to the learners the abstract concepts by means of experiments. It also requires the educators to combine what they are taught in the classroom with the laboratory experiments using the science resources for the deep understanding of the concepts. This study revealed that the teaching of Physical Sciences using laboratory resources and combining it with the theory plays a major role in successful teaching and learning. The study also showed that teaching and learning are more enjoyable when the learners learn by doing the experiments using Physical Sciences resources. Therefore, educators and learners should not treat what is taught in the laboratory using Physical Sciences resources as an approach that is different from what is taught in the classroom. The theory and the practical work need to be linked to each other. The information gained by the learners

when they do the experiments themselves is retained more effectively because the learners have a greater responsibility for their own learning.

This study showed that learner achievement in Ohm's law in the resourced school is considerably greater than the achievement of learners from the under-resourced school. The collected data indicated that when learners do an experiment themselves they have a greater interest in the subject. Their curiosity is aroused because they are actively involved in the process of their learning and they are learning as they are doing the practical work. Learners are thus equipped with a number of skills like problem solving, data analysis and data interpretation.

The use of resources in the teaching and learning of Physical Sciences is important because it improves the performance of the learners and leads to lasting understanding. More Physical Sciences topics should be taught practically using Physical Sciences resources. The Department of Education should organise workshops and in-service training for educators to assist the educators in using and managing Physical Sciences resources. The Department of Education should try by all means to assist the educators with limited laboratory skills and even those with skills must be encouraged to further their skills and transfer them to their learners and to other educators.

The Department of Education should build fully equipped laboratories in each district. These laboratories should be supported by nearby Universities. These laboratories should be used for the training of the educators in those Physical Sciences topics that require practical experiments. Qualified laboratory assistants should be employed so that they can assist the subject advisors when training the educators and assist the educators with the management of the laboratory equipment and chemicals.

This study has implications for the government, national and provincial Education Departments in the supply to schools of fully equipped laboratories and the training of

educators on how to use Physical Sciences equipment. Educators in turn should implement what they learn in the transfer of those skills to learners. The learners could obtain a better understanding and their achievement could improve especially in those questions which are based on practical work.

The reason why the Department of Education is advised to supply all the schools that are offering Physical Sciences with laboratories that have resources is that laboratories create a positive teaching and learning environment. Constant support and training to Physical Sciences educators from school administrators and subject advisors is needed to ensure the implementation of the laboratory investigations in each school. Well trained and qualified laboratory assistants and technicians should be employed to assist the educators and learners in setting up the apparatus in the laboratory. It is time-consuming to for the learners to collect the apparatus, do the experiments and come up with conclusions on their own. The laboratory assistants should also assist the educators and the learners in showing them on how to use the available Physical Sciences resources in a school so that extra time for teaching and learning is available.

The study could also encourage schools which are under-resourced to build partnerships with neighbouring schools which have resources so that they have access to Physical Sciences equipment. The Department of Education should supply all the schools with mobile laboratories. The Physical Sciences educators should form part of the school management team so that they can be in a position to address the needs of Physical Sciences. When a school budget is drawn up there should be a certain percentage of money allocated for buying Physical Sciences equipment because almost all the schools are section 21 schools. Maximum support should be given to those educators from under-resourced schools and the educators from the resourced schools should be encouraged to assist those with no resources. Schools close to each other especially those with Physical Sciences resources and the ones without the resources should build a partnership so that they can be in a position to share the minimum resources they have for the maximum benefit of the learners.

The study also has implications for educators who are new to the teaching of Physical Sciences in suggesting that they cluster with those that have experience and sufficient skills in teaching using the Physical Sciences resources. It is also recommended that if a school is under-resourced a Physical Sciences educator should improvise where possible to obtain everyday resources to teach the topic.

It is further recommended that the educators within a district work as a team when planning what is to be taught, sharing some important ideas about the Physical Sciences topics and strategies on how to tackle the difficult topics. There should be some provision of the necessary resources to schools by the Department of Education. The District officials should organise professional development programmes and should come up with means and strategies to fund and manage them. They should attempt to ensure that all the Physical Sciences educators participate in activities that foster professional growth and try new teaching methods and approaches. There should also be regular evaluation of the success of the new methods.

Darling-Hammond and McLaughlin (1995) highlight that professional development must be effective and further outlined that educators must be hands-on doing practical activities, look at what they are doing, analyse their work and come up with conclusions. The type of professional development should be one that will allow educators to share their ideas, one that is an on-going process and which encourages educators to be intrinsically motivated.

Students who are studying Physical Sciences should be given opportunities to handle and manipulate laboratory equipment, use scientific reasoning and help the learners to work independently and collaboratively. There should be on-going training in laboratory logistics such as setup and safety equipment management so that the educators are well informed about the safety procedure changes so as to ensure maximum protection. Safety training and safety equipment should be provided. Physical Sciences educators

should be given time so that the learners who are studying Physical Sciences can be in a position to do their practical work and be able to design, conduct, analyse, complete the investigation, reason scientifically and communicate by writing a report.

The approach used in the laboratory is learner-centred where the learners are given a chance to link the theory they have been taught into practice in order for them to have a better understanding of the concepts. The effectiveness of this approach is to provide the learners who perform poorly the opportunity to participate in the activities and work as individuals. Learners can apply the academic knowledge gained through scientific inquiry to real life problems because as an educator you have to teach the learners in order to prepare them for work and for society (linking school knowledge to everyday knowledge).

The shortage of fully equipped laboratories had a negative impact on learner performance. If there is laboratory equipment for Physical Sciences in a school, there is an opportunity to increase learner performance especially in questions which are based on scientific inquiry. The research showed that Physical Sciences equipment plays a major role in enhancing teaching and learning. Physical Sciences is not a theoretical subject it needs learners to be engaged in practical hands-on activities. The learners should be taught using concrete materials as early as primary school level because the teaching of science using the resources is then more enjoyable and meaningful to the learners.

In addition to the teaching hours there should be time allocated in a school time table so that the learners can be taught using the resources. Sometimes the Physical Sciences educators are advised to teach during extra hours and even on Saturdays. The reason behind this is that learners require more time when they learn by doing experiments and they learn at their pace. There are steps that need to be followed when the educator is teaching using the resources. The first step is to teach the learners the safety precautions for the experiment, then teach them how to handle the apparatus, next how to use the resources and to guide the learners on how to do the experiment using the available

resources. This time-consuming process requires the educator to be in discreet control and management of his or her class at all times.

### **6.5 Limitations of the study**

The results of this study were obtained from the sample of sixty learners from the resourced school and thirty-nine learners from the under-resourced school. The sample is very small and the results from it cannot be generalized. The data collected from the two schools in one district in Grade 10 classes is not sufficient to provide solutions for the whole district and for other grades. The problem of the poor pass rate in Physical Sciences is a national problem so to address it in two rural schools in one district cannot solve the problem nationally, since the schools' context and their socio-economic backgrounds may not be similar to other schools in the Eastern Cape Province and other parts of the country. The results obtained from the study might not be replicated elsewhere.

The educators were observed only whilst teaching electricity for a short period of time. Mateu (2014) reveals that when the data are collected in few places, few people and few objects, the data collected are not enough as it addresses only those problems and provides conclusions and solutions for only those in that particular area. Time constraints is a major challenge when conducting research, according to Mpofu (2006). His statement is in line with that of Mateu (2014). Time to conduct this research was insufficient because it depended on the amount of time that the researcher was given by the principal of the schools. As it was indicated that the researcher should not disturb the teaching programme and other subjects must not be affected. In rural schools where the research was conducted, the majority of the Grade 10 learners live far from school so there were difficulties in organizing time to conduct the research.

The study was conducted in two rural schools, the findings are specific for rural schools only in the Eastern Cape Province, so they cannot be extrapolated to urban schools and

former model C schools. Since IsiXhosa is the home language of the participants and English is their first additional language, the use of the first additional language in this study may have influenced the results to some extent. The correct interpretation of a question plays a vital role in the achievement scores of the learners.

## **6.6 Recommendations for future research**

Future studies could make use of a bigger sample and also could be conducted in other grades to obtain a more comprehensive picture of the applications in resourced and under-resourced schools. A follow up study that could look at clusters of schools in the district to observe the practices of a wider group of educators and the strategies they follow is needed. In this study the two schools followed a typical resourced and under-resourced pattern. There may be other under-resourced schools that have developed various strategies to overcome their lack of resources which could have implications for future teaching of practical-based subjects like Physical Sciences.

## **6.7 Conclusion**

This study investigated the teaching and learning of Ohm's law in Physical Sciences in resourced and an under-resourced school. The findings and conclusions drawn were based on the data that were collected in the two schools. The study clearly demonstrated the importance of the use of resources, in this case, electricity equipment in positively influencing learners' achievement and understanding in Physical Sciences.

## REFERENCES

- Abrahams, I., & Millar, R. (2008). Does practical work really work? A study of the effectiveness of practical work as teaching and learning method in school science. *International Journal of Science Education Laboratory*, 30(14), 1945-1949.
- Adolphus, T., & Aderonmu, T.S.B. (2013). Difficulties students encounter in reporting physics practical at the senior secondary school level in Rivers State, Nigeria. *Asian Journal of Education and e-Learning*, 1(1), 29-33.
- Akatugba, A.H. & Wallace, J. (1999). Sociocultural influences on physics students' use of proportional reasoning in a non-Western country. *Journal of Research in Science Teaching*, 36(3), 305-320.
- Akinyeye, C.M. (2012). *Investigating approaches to the teaching of writing in English as a second Language in senior phase classroom in the Western Cape*. A thesis submitted in the fulfillment of the requirements of the degree of Masters in English. University of the Western Cape.
- Arena, A. (1996). The role of relevance in the acquisition of science process skills. *Australian Science Teachers Journal*. 42(4), 34-38.
- Asan, A. (2007). Concept mapping in science class: A Case Study of fifth grade student. *Education Technology & Society*, 10(1), 186-191.
- Atherton, J. S. (2011). *Learning and Teaching: Constructivism in learning*. Available: < <http://www.learningandteaching.info/learning/constructivism.htm>>. [Accessed: 25 Apr 2012].
- Ausubel, D. (1963). *The Psychology of Meaningful Verbal Learning*. New York: Grune & Stratton.
- Awotua, E.B., Williams, C., & Aderonmu, T.S.B. (2015). Towards an Enhanced Performance in Physics Practical: The Micro science Kits Experience. *International Journal of Education and Research*, 3 (4), 29.

- Babbie, E. & Mouton, J. (2010). *The Practice of social research (12<sup>th</sup>ed)*. California: USA: Wadsworth. Cengage Learning.
- Balgopal, M.M. (2014). Learning and intending to teach evolution: Concerns of pre-service biology teachers. *Research in Science Education*, 44(7), 27-52.
- Barber, M., & Mourshed, M. (2007). *How the world's best-performing school systems come out on top*. McKinsey & Company.
- Berg, L.B. (2001). *Qualitative research methods for Social Science (4<sup>th</sup>ed)*. Toronto: Allyn & Bacon.
- Biggs, J. (2003). *Teaching for quality learning at university*. Great Britain: Cromwell Press.
- Blok, J. (1982). Assimilation, Accommodation and the Dynamics of Personality Development. *Child Development*, 53(1), 281-295.
- Bogdan, R. C., & Biklen, S. K. (1982). *Qualitative research for education: An introduction to theory and methods*. Boston: Allyn and Bacon.
- Bollen, K. A. (1989). *Structural Equations with Latent Variables*. New York: John Wiley & Sons.
- Bradley, J.D. & Smith, C. (1994). *Pre-service teacher education and high school practical work in M.J. Glencross (2 ed.)*, Proceedings of the Second Annual Meeting of the Southern African Association of Research in Mathematics and Science Education. University KwaZulu-Natal.
- Britten, N. (1995). Qualitative interviews in medical research. *British Medical Journal*. 311, (6999), 251-253.
- Brooks, M.G., & Brooks, G.J. (1999). The Courage to be a Constructivist. *The Constructivist Classroom*. 57, (3), 18-24.
- Bryman, A. (2008). *Social research methods (3<sup>rd</sup>ed.)*. Oxford: Oxford University Press.

California Department of Education, Frameworks.<http://www.cde.ca.gov/ci/cr/cf/index.asp>.

Cerini, B., Murray, I., & Reiss, M. (2003). Student Review of the Science Curriculum: Major Findings, Planet Science, London. Available at <http://www.planetscience.com/sciteach/review/Findings.pdf>.

Cohen, L., Manion, L., & Morrison, K. (2007). *Research Methods in Education*. New York: Routledge.

Colburn, A., & Clough, M. P. (1997). Implementing the Learning Cycle. *The Science Teacher*, 64(5), 30-33.

Coleman, L.A., Holcomb, D.F., & Rigden, J.S. (1997). The introductory university project 1987-1995: What has it accomplished? *American Journal of Physics*, 66(2), 124-137.

Colen, L., Marion. L., & Morrison, K. (1980). *Structural Equations with Latent Variables: A Guide to teaching practice*. London and New York: Routledge and Falmer.

Creswell, J. (2009). *Research Design, Qualitative and Quantitative and Mixed Methods Approaches*. London: Sage Publications.

Dadach, Z.E. (2013). Quantifying the Effects of an Active Learning Strategy on the Motivation of Students. *International Journal of Engineering Education*, 29(4), 904–913.

Dale, E.C. (1969). *Audio-visual methods in teaching*. [SI] London: Holt Rinehart and Winston.

Darling-Hammond, L., & McLaughlin, M.W. (1995). Policies that support Professional development in an era of reform. *Phi Delta Kappan*, 76(8), 567-606.

Department of Basic Education. (2011). *Action Plan to 2014: Towards the Realization of Schooling 2025*. Pretoria: Department of Basic Education.

Department of Basic Education, (2011). *Curriculum and Assessment Policy Statement. Physical Sciences (CAPS)*. Pretoria: Department of Education.

- Department of Basic Education. (2016). *Information Guide for 17<sup>th</sup> Annual National Teaching Awards*. Republic of South Africa. Department of Basic Education.
- Department of Education. (2003). *National Curriculum Statement Grade 10-12 (General)*. Pretoria: Government Printer.
- Department of Education. (2002). *Revised National Curriculum Statement for Grades R-9 (Schools)*. Natural Sciences. Pretoria: Government printer.
- Derry, G.N. (1999). *What science is and how it works?* Princeton, NJ: Princeton University Press.
- Dhurumraj, T. (2013). *Contributing Factors to poor Performance in Physics Sciences in Kwazulu Natal with Special Reference to Schools in the Pinetown*. South Africa: University of South Africa.
- Donald, D., Lazarus, S., & Lolwana, P. (2010). *Educational psychology in social Context: Ecosystemic application in Southern Africa*. South Africa: Oxford University Press.
- Dreckmeyer, M. (1994). *Successful science teaching*. Pretoria: Kagiso.
- Dunnie, J. (2013). *An exploration of an Inquiry Based Science Education in Irish Primary Schools*. Submitted for the degree of Doctor in Philosophy. University of Limerick.
- Dzama, N, & Osborne, J.F. (1999). Poor performance in science among Africa students: An alternative explanation to the Africa worldview thesis. *Journal of Research in Science Teaching*, 36(3), 387-405.
- Eisner, E.W. (1985). *The Educational immigration: On the design an evaluation of school programmes (2<sup>nd</sup>ed.)*. London: Collier Macmillan.
- Fisher, D., Fraser. B. & Henderson, D. (2007). Laboratory environment and student outcomes in senior high school Biology. *Journal for American Biology teacher*, 59 (4), 214-219.
- Fox, N. (1998). *Trent Focus for Research and Development in Primary Health Care. How to use Observation in a Research Project?* Trent Focus.

- Frankfort-Nachmias, C., & Leon-Guerrero, A. (1997). *Social statistics for a diverse Society*. Thousand Oaks, CA: Pine Forge.
- Frederiksen, J. R., White, B. Y., & Gutwill, J. (1999). Dynamic mental models in learning Science: The importance of constructing derivational linkages among models. *Journal of Research in Science Teaching*, 36, 806–836.
- Freebody, P.R. (2003). *Qualitative Research in Education. Interaction and practice*. London: Sage Publications Ltd.
- Goodwin. (2014). *The intelligibility of gestures within a framework of co-operative action. In from gestures in conversation to visible action as utterance*. Essays in honor of Adam Kendon, Amsterdam, and John Benjamin's publishing company.
- Gott, R., & Duggan, S. (2007). A framework for practical work in science and scientific literacy through argumentation. *Research in Science and Technological Education*, 25(3), 271-291.
- Grennon Brooks, J., & Brooks, M. G. (1993). *In search of understanding: The case for constructivist classrooms*. Alexandria, VA: ASCD.
- Gunstone, R., Mulhall, P., & McKittrick, B. (2009). Physics teachers' perceptions of the difficulty of teaching electricity. *Research in Science Education*, 39, 515–538.
- Hampden-Thompson, G., & Bennet, J. (2013). Science Teaching and Learning Activities and Students' Engagement in Science. *International Journal of Science Education*, 35(8), 1325-1343.
- Harrington, N., & Terry, C.L. (2009). *LPN to RN Transitions: Achieving Success in Your New Role (3<sup>rd</sup> ed)*. Philadelphia, USA: Wolters Kluwer Health.
- Harrison, A. (2002). "Case Study Research". In Partington, D. (Ed), *Essential Skills for Management Research*. London: Sage Publications.
- Hartley, M.S. (2014). Creating a vibrant learning environment for the teaching and learning of science and technology: *Proceedings of the Eastern Cape South African association of Science and technology Educators 2014 Conference* (pp1-10). Mthatha: Eastern Cape.

- Hartley, M.S. (2013). *Bachelor of Education (Hons) in Science Education: Science Education University of the Western Cape.*
- Henning, E., Van Rensburg, W., & Smit, B. (2004). *Finding your way in qualitative research.* Pretoria: Van Schaik Publishers.
- Hoepfl, M.C. (1997). Choosing Qualitative Research: A Primer for Technology Education Researchers. *Journal of Technology Education, 9(11)*, 11-26.
- Hofstein, A., & Lunetta, V.N. (2004). The Laboratory in Chemistry Education: Thirty Years of Experience with Developments, Implementation, and Research. *Chemistry Education: Research and Practice, 5*, 247-264.
- Hofstein, A., & Lunetta, V. N. (1982). The role of the laboratory in science teaching: Neglected aspects of research. *Review of Educational Research, 52(2)*, 201–217.
- Hofstein, A., & Mamlok-Naaman, R. (2007). The laboratory in science education: The state of the art. *Chemistry Education Research and Practice, 8 (2)*, 105-107.
- Jaakkola, T., Nurmi, S., & Veermans, K. (2011). A comparison of students' conceptual Understanding of electric circuits in simulation only and simulation-laboratory contexts. *Journal of Research in Science Teaching, 48*, 71–93.
- Johannes, E. A. (2005). *Using collaborative action Research to improve classroom discipline: An Action Research Study in a secondary school in the Bolland.* A mini thesis in Faculty of Education, University of the Western Cape.
- Johnson, R.B., & Christensen, L. B. (2004). *Educational Research: Quantitative, qualitative and Mixed Approaches.* Boston MA: Allyn & Bacon.
- Johnson, R.B. & Christensen, L. B. (2012). *Educational Research (4<sup>th</sup>ed).* Los Angeles, CA: Sage.
- Johnson, R.B., & Turner, L.A. (2003). *Data collection strategies in mixed methods research. Handbook of mixed methods in social and behavioral research.* Thousand Oaks, CA: Sage.
- Joppe, M. (2000). *The Research Process.* Retrieved February 25, 1998 from <http://www.ryerson.ca/~mjoppe/rp.htm>.

- Kelder, K.H. (2012). *Study & Master Physical Science, Grade 11. Learner's book*. Cape Town: Cambridge University Press.
- Kelly, G. J., & Crawford, T. (1996). Student interaction with computer representations analysis of discourse in laboratory groups. *Journal of Research in Science Teaching, 33*(7), 693-707.
- Kibirige, I., & Hodi, T. (2013). Learners' Performance in Physical Sciences Using Laboratory Investigations. *International Journal of Educational Sciences, 5*(4), 425-432.
- Kim, M., & Chin, C. (2011). Pre-service teachers' views on practical work with inquiry Orientation in textbook-orientated science classroom. *International Journal of Environmental and Science Education, 6* (1), 23-37.
- Kolloffel, B., & Jong, T. (2013). Conceptual understanding of electrical circuits in secondary vocational Engineering Education: Combining Traditional Instruction with Inquiry Learning in a Virtual Lab. *Journal of Engineering Education, 102* (3), 375-393.
- Kolucki, B., & Lemish, D. (2011). *Communicating with Children Principles and Practices to Nurture, Inspire, Excite, Educate and Heal*. UNICEF. From [http://www.unicef.org/cbsc/files/CwC\\_Web.pdf](http://www.unicef.org/cbsc/files/CwC_Web.pdf) Accessed 23 May 2014.
- Koshy, V. (2010). *Action research for improving educational practice*. Los Angeles: Sage.
- Krajcik, J., Mamlok, R., & Hug, B. (2001). Modern content and the enterprise of science: Science education in the twentieth century. In L. Corno (Ed.), *Education across a century: The centennial volume* (pp. 205–238). 100th Yearbook of the National Society for the Study of Education. Chicago: University of Chicago Press.
- Kriek, J., & Grayson, D. (2009). A Holistic Professional Development model for South African Physical Science teachers. *South African Journal of Education, 29*(9), 185-203.
- Kvale, S. (1996). *Interviews-an Introduction to Qualitative Research Interviewing*. London: Sage Publications.

- Lazarowitz, R. (1998). *Cooperative learning in the science curriculum*. In: BJ Fraser, K.G. Tobin (Eds.): *International Handbook of Science Education*. Dordrecht, Netherlands: Kluwer Academic Publishers.
- Lincoln, Y. S., & Guba, E. G. (1985). *Naturalistic inquiry*. Beverly Hills, CA: Sage Publications.
- Lowery, L.F. (1994). Inquiry: The Emphasis of a Bold, New Science Curriculum. *Educational Technological Horizons in Education*, 21(8), 50-52.
- Lunetta, V.N., Hofstein, A., & Clough, M.P. (2007). *Teaching and learning in the school science laboratory. An analysis of research, theory, and practice*. In, S. K. Abell and N. G. Lederman (Eds), *Handbook of Research on Science Education*. Mahwah, NJ: Lawrence Erlbaum Associates.
- Maqutu, T. (2003). Explaining success in O-level physical science in Lesotho: a survey of physical science teachers. *African Journal of Research in Mathematics, Science and Technology Education*, 7, 97–107.
- Marshall, C., & Rossman, G.B. (1999). *Qualitative Research (3<sup>rd</sup>ed)*. Thousand Oaks, CA: Sage.
- Mateu, D.M. (2014). *An investigation into the impact of globalization on the intergenerational of transmission of oral literature in Namibia: A community based education perspective*. A thesis submitted to the department of Language Education, Faculty of Education in fulfillment of the requirement for the degree of Masters in Education. University of the Western Cape.
- Mathews, P. (2008). *Advanced Chemistry*. Cambridge, UK: Cambridge University Press.
- Mavhunga, F. (2014). Effect of Practical Work on Grade 10 Learners' Performance in Science in Mankweng Circuit, South Africa. *Department of Mathematics Science and Technology Education, University of Limpopo*, 5(23), 1568.
- Mbano, N. (2004). Pupil's thinking whilst designing an investigation. *Journal of Research in SMT Education*, 8(2), 105-114.

- McDermott, L. C. & Shaffer, P. S. (1992). Research as a guide for curriculum development: An example from introductory electricity. Part I: Investigation of student understanding. *American Journal of Physics*, 60, 994–1003.
- Mchunu, S.P. (2009). *Challenge facing Physical Science educators in the implementation of the national Curriculum Statement: The case study of the Impangeni Education district*. A dissertation submitted to the Faculty of education in fulfillment of the requirements for the Degree of Master of Education (Science Education) in the Department of Mathematics, Science and Technology Education. Kwazulu Natal: University of Zululand Kwadlangezwa.
- Mertler, C., & Charles, C.M. (2005). *Introduction to Education Research (5<sup>th</sup>ed)*. New York: Pearson.
- Mhlongo, M.R. (2010). *The contribution of simulation to the practical work of foundation Physics students at the University of Limpopo*. A thesis submitted in part of fulfillment of the requirements for the degree of Master of Science in Mathematics, Science and Technology education in the subject Physics Education. Republic of South Africa: University of South Africa.
- Michel, N.J., Cater, J., & Varela, O. (2009). Active versus passive. Teaching styles: an empirical study of student learning outcomes, Small Business Institute 1. *National Proceedings*, 33(1), 397–418.
- Millar, R. (2004). *The role of practical work in the teaching and learning of science. In high school science laboratories: role and vision*. National academy of sciences, Washington, DC.
- Mji, A. & Makgato, M. (2006). Factors associated with high school learners' poor performance: A spotlight on mathematics and physical science. *South African Journal of Education*, 26(2), 253–266.
- Mkandawire. (2009). *Physical Science activities and skills development in the school curriculum of Namibia*. A thesis submitted in partial fulfillment of the requirements for the degree of Masters of Education with specialization in natural science education. University of South Africa.

- Mkonto, P.N. (2010). *The development & evaluation of learning style assessment tools for the South African higher education*. A thesis submitted in fulfillment of the requirement for a Doctor in Philosophy in the faculty of education. Western Cape: University of the Western Cape.
- Moodley.K. (2013). *The relationship between teachers' ideas about teaching electricity and their awareness of learner's misconceptions*. Department of Science, Maths and Technology Evaluation. Faculty of Education University of Pretoria.
- Morgil, I., Gungor, S. H., & Secken, N. (2009). Investigating the Effects of Project-Oriented Chemistry Experiments on some Affective and Cognitive Field Components. *Journal of Turkish Physics Education*, 6, 108-114.
- Motshekga, A.M. (2013). *National Diagnostic Report on learner performance*. Department of Basic Education publisher. Republic of South Africa.
- Mouton, J., and Marais, H.C. (1994). *Basic Concepts in the methodology of Social Sciences*. Pretoria: Human Sciences Research Council.
- Mpofu, N.V. (2010). *Grade 12 students' conceptual understanding of chemical reactions: A case study of fluoridation*. A thesis submitted in partial fulfillment for the Masters in education. University of the Western Cape.
- Musasia, A.M., Abacha, O.A, & Biyoyo, M.E. (2012). Effect of Practical Work in Physics on Girls' Performance. Attitude change and Skills acquisition in the form two-form three Secondary Schools' transition in Kenya. *International Journal of Humanities and Social Science*, 2 (23): 151-166.
- Muwanga-Zake, J. W. F. (2006). *What kind of science do educators present to learners in South African classes?* Research portfolio submitted as partial fulfillment of the requirements for the award of a degree of Master of Education. Rhodes University.
- Ngema, S.H. (2011). *An exploration of grade 11 teachers' conceptions of practical work in Physical Sciences within the National Curriculum Statement (NCS)*. A Research Report Submitted in Partial Fulfillment of the Requirements for the degree of

- Masters in Education. School of Science, Mathematics and Technology Faculty of Education. University of Kwa Zulu Natal.
- Ojediran, I. A., Oludipe, D. I., & Ehindero, O. J. (2014). Impact of Laboratory-Based Instructional Intervention on the Learning Outcomes of Low Performing Senior Secondary Students in Physics. *Creative Education*, 5, 197-206.
- Okanlawon, A.E. (2012). Chemistry lecturers' perceptions of "critical barriers" to successful solving of acid-base titration problems. *African Journal of Research in Maths, Science and Technology Education*, 16 (3), 390–404.
- Onwioduokit, F.A (2013). *The ordeal of science teaching in the contemporary society: A need for paradigm shift for the new generation*. A professorial inaugural lecture (series 36th) delivered on January 31st, 2013. University of Uyo, Nigeria.
- Onwu, G., & Stoffels, N. (2005). Instructional functions in large, under-resourced: science classes: Perspectives of South African teachers. *Perspect in Education*, 23, 79-91.
- Ottander, C., & Grelsson, G. (2006). Laboratory work: The teachers 'perspective. *Journal of Biology Education*, 40(3), 113–118.
- Paris. Organization for Economic Cooperation and Development (2005). *Teachers Matter: Attracting, Developing and Retaining Effective teachers*.
- Perkins, D. (1993). Teaching for understanding. *The Professional Journal of the American Federation of Teachers*, 17(3), 28 -35.
- Phillips, D.C. (1995). The Good, the Bad, and the Ugly: The Many Faces of Constructivism. *American Educational Research Association*, 24(7), 5-12.
- Piaget J. (1976). *The Grasp of Consciousness*. Cambridge, MA: Harvard University Press
- Porta, M.A. (2008). *Dictionary of Epidemiology*.5. Oxford: Oxford University Press.
- Powell, K.C., & Kalina, C.J. (2013). Cognitive and social constructivism: Developing tools for an effective classroom. *Science Education*, 130(2), 110-121.
- Prophet, R.B. (1990). Rhetoric and reality in science curriculum development in Botswana. *International Journal of Science Education*. 12, (1), 13-23.

- Qhobela, M. & Moru, K.E. (2011). Learning physics through argumentation at secondary school level in Lesotho: A feasible teaching strategy? *African Journal of Research in Maths Science and Technology Education*, 15(2), 205–220.
- Rankhumise, M.P. (2012). *The effect of activity-based instructional approaches in ameliorating alternative conceptions about electric circuits held by students from the national curriculum statement and the old school curriculum*. Department of Mathematics, Science and Technology Education. Faculty of Education, University of Zululand.
- Republic of South Africa. Department of Basic Education. (2014). *National Senior Certificate Chief Marker's Report grade.2014-2016*. Retrieved from <http://www.ecdoe.gov.za>
- Republic of South Africa. Department of Basic Education. (2016). *National Senior Certificate Diagnostic Report 2013-2016*. Retrieved from <http://www.ecdoe.gov.za>.
- Robottom, I. (2004). Constructivism in Environment Education: Beyond Conceptual Change Theory. *Australian Journal of Environmental Education*, 20 (2), 93-101.
- Romanelli F, (2009). Learning Styles: A Review of Theory, Application, and Best Practices. *American journal of pharmaceutical education*, 19; 73(1): 09.
- Rossouw, D. (2005). *Intellectual tools. Skills for the human science*. Pretoria: Van Schaik Publisher.
- Roychoudhury, A. (1995). Interaction in an open-inquiry physics laboratory. *International Journal of Science Education*, 18(4), 423-445.
- Sayser, N.J. (2014). *Development of an instrument that supports and monitors inclusive cultures, policies and practices in a Western Cape school. Thesis submitted in fulfillment of the requirement for the degree of Masters of Education*. University of the Western Cape.

- Stoffels, N.T. (2005). "There is a worksheet to be followed": A case study of a science teacher's use of learning support texts for practical work. *African Journal of Research in SMT Education*, 9(2), 147-157.
- Strauss, A., & Corbin, J. (1990). *Basics of qualitative research: Grounded theory procedures and techniques*. Newbury Park, CA: Sage Publications.
- Taber, K.S. (2006). Beyond Constructivism: The Progressive Research Programmed into learning Science Studies in Science Education. *Science education*, 42, 125-184.
- Terhart, E. (2003). Constructivism and teaching: A new paradigm in general didactics? *Journal of Curriculum Studies*, 35(1), 25-44.
- Thornton, R.K. (1987). Tools for scientific thinking: Microcomputer-based laboratories for Physics teaching. *Physics Educator*, 22(4), 230-238.
- Tinker, R.F. (1981). Microcomputers in the teaching laboratory. *The Physics Teacher*, 19(2), 94-105.
- Tobin, K.G. (1990). Research on science laboratory activities; in pursuit of better questions and answers to improve learning. *School Science and Mathematics*, 90(3), 403-418.
- Toplis, R. (2012). Students' views about secondary school science lessons: The role of practical work. *Research in Science Education*, 42(3), 531-549.
- Toplis, R., & Allen, M. (2012). 'I do and I understand?' Practical work and laboratory use in United Kingdom schools. *Eurasia Journal of Mathematics, Science & Technology Education*, 8(1), 3-9.
- Tsai, C. (2003). Taiwanese science students' and teachers' perceptions of the laboratory learning environments: Exploring epistemological gaps. *International Journal of Science Education*, 25(7), 847-860.
- Vygotsky, L.S. (1978). *Mind in society. The development of higher psychology processes*. Cambridge, Mass: Harvard University Press.

- Washington. National Academy Press .National Research Council. (2006). *Americas' Lab. Report: Investigations in High School Physics*.
- Wellington, J., & Ireson, G. (2008). *Science Learning, Science Teaching. (1<sup>sted</sup>)*. New York: Routledge.
- Wesi, R.P. (2001). *Higher Diploma in Education for Physical Science teachers*. Workbook for Subject for didactics. Northwest University.
- Wesi, R.P. (1997). *Conceptualization of core concepts in electricity by Physical Science teachers*. M.Ed. Dissertation, Potchefstroom University for Christian Higher Education.
- Woodley, E. (2009). Practical work in school science-why is it important? *School Science Review*, 91(335), 48-51.
- Woolfolk, A. (2004). *Educational psychology*. Boston, MA: Pearson Allyn & Bacon
- World Economic Forum. 2014. *The Global Competitiveness Report 2014–2015*: World Economic Forum. Geneva.
- Yin, R. (1994). *Case study research: Design and methods*. Los Angeles. London, New Delhi, Singapore, and Washington DC: Sage Newbury, CA: Sage Publishing
- Zacharia, Z.C., & Anderson.O.R. (2007). the effects of an interactive computer- based simulation prior to performing laboratory inquiry-based experiments on students' conceptual understanding of physics. *American Journal of Physics*, 7,618-629.
- Zimbardi, K., Bugarcic, A., Colthorpe, K., Good, J.P. & Lluka, L.J. (2013). A set of vertically integrated inquiry-based practical curricula that develop scientific thinking skills for large cohorts of undergraduate students. *Advances in Physiology Education*, 37(4), 303-315.

## APPENDICES

### Appendix A:

#### Observation schedule for educators

Observation Schedule: Nomawethu Thelma Mngonyama

Study Title: Comparing the teaching and learning of Ohm's law Physical Science in resourced and under- resourced schools

CONTENT KNOWLEDGE	COMMENTS
1. Outcomes of the lesson clearly stated.	
2. Introduction of the lesson well done.	
3. Availability of resources.	
4. Resources for the lesson were introduced to the learners.	
5. Educator clearly guides the learners in the handling of apparatus.	
6. Lesson introduction was linked to the resources used and lesson presentation.	
7. Learners were allowed to construct their own understanding	
8. Educator acknowledges and respects individuality and diversity.	
9. Approach used.	
10. Strategies used for teaching.	
11. Teacher was creative and innovative.	
12. Learner interaction with each other.	
13. Promotion of positive classroom behaviour.	
14. Management of group work.	
<b>LEARNER ASSESSMENT</b>	
15. Use of range of assessment methods and techniques.	
<b>GENERAL COMMENTS</b>	

**Appendix B:**

The format of the worksheet that was used for the experiment.

**GRADE 10                      2016    EXPERIMENT**

**Date:**

**Total: 24**

**Surname of the learner: Name:**

**1. Topic**

---

To investigate the relationship between potential difference and current.

---

---

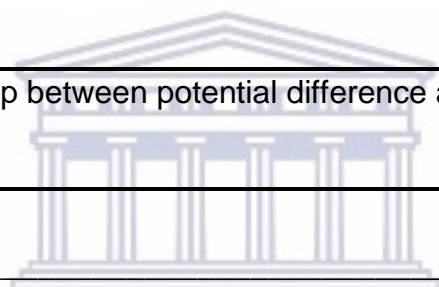

UNIVERSITY *of the*  
WESTERN CAPE

**2. Aim**

**(2)**

---

---

**3. Apparatus used.**

(4)

---

#### 4. Procedure

---

(4)



UNIVERSITY *of the*  
WESTERN CAPE

#### 5.1 Data collection

---

Potential difference(V)	Current(A)
1.	
2	
3.	

(6)

**5.2. Observations.**

(2) \_\_\_\_\_

---

---

---

---

**5.3 Sketch the circuit diagram.**

(4)

**6. Write down your conclusion.**

(2)

---

---



UNIVERSITY *of the*  
WESTERN CAPE

**Appendix C:**

**Test questions**

**Ohm's law test**

**Marks: 40**

**Table 5**

QUESTIONS	SCHOOL A RESOURCED Number of learners Correct	SCHOOL B UNDER-RESOURCED Number of learners Correct
<p>QUESTION.1 MULTIPLE CHOICE</p> <p>1.1The SI unit for current is a A.volt. B ohm C. Ampere D. seconds(2)</p>		
<p>1.2 Which one of the variables is a control variable for the experiment showing the relationship between potential and current? A. Current D. Thermometer B. Temperature C. Potential difference (2)</p>		
<p>QUESTION 2. Give one word for each of the following phrase.</p> <p>2.1 The rate at which charge flows.(2) 2.2.The opposition to the flow of charge(2)</p>		
<p>QUESTION 3 LONG QUESTIONS Grade 10 learners set up the apparatus to conduct an experiment that shows</p>		

<p>the relationship between current and potential difference.</p> <p>They obtained the following results</p> <table border="1"> <thead> <tr> <th>V(v)</th> <th>I(A)</th> </tr> </thead> <tbody> <tr> <td>1. 1.5</td> <td>2</td> </tr> <tr> <td>2. 3</td> <td>3.5</td> </tr> <tr> <td>3. 4.5</td> <td>5</td> </tr> </tbody> </table>	V(v)	I(A)	1. 1.5	2	2. 3	3.5	3. 4.5	5		
V(v)	I(A)									
1. 1.5	2									
2. 3	3.5									
3. 4.5	5									
<p>3.1 List all the relevant apparatus that are needed to conduct the experiment. (3)</p>										
<p>3.2 With the help of the table above write down the noticeable relationship between current and potential difference. (3)</p>										
<p>3.3 Name the law which is investigated in the experiment above? (2)</p>										
<p>3.4 State the law mentioned in 3.3(3)</p>										
<p>3.5. Graphically represent the information given in the table above by clearly indicating the dependent and independent variables. (4)</p>										
<p>3.6 What is the mathematical relationship between potential difference and current represented by the shape of the graph? (2)</p>										
<p>3.7 In not more than five sentences explain how the learners will use the apparatus in 3.1 when conducting the experiment. (4)</p>										

3.8 Draw the circuit diagram to show how to connect the mentioned apparatus. (4)		
3.9 Use the graph drawn in 3.5 to calculate the gradient?(4)		
3.10 What does the inverse of the gradient represent?(2)		
3.11 What will happen to electricity in a house when you plug more appliances into one socket? (3)		



UNIVERSITY *of the*  
WESTERN CAPE

## Appendix D:

### Test memorandum

#### Question 1

1.1 C ✓✓ 1.2 B ✓✓

#### Question 2

2.1 Current. ✓✓ 2.2 Resistance. ✓✓

#### QUESTION 3

3.1 Ammeter ✓, voltmeter, ✓ batteries, connecting wire. ✓

3.2 Potential difference is directly proportional to the current or as potential difference increases current also increases. ✓✓✓

3.3 Ohm's law. ✓✓

3.4 Current in a metallic conductor is directly proportional to the potential difference provided that temperature remains constant. ✓✓✓

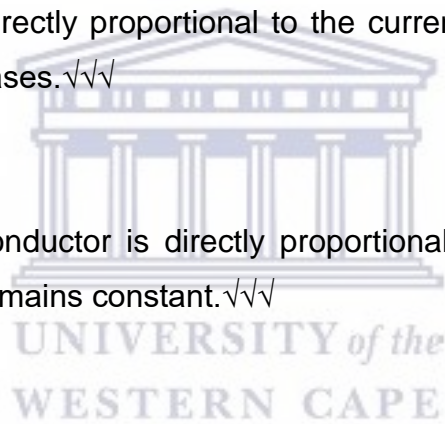

3.5

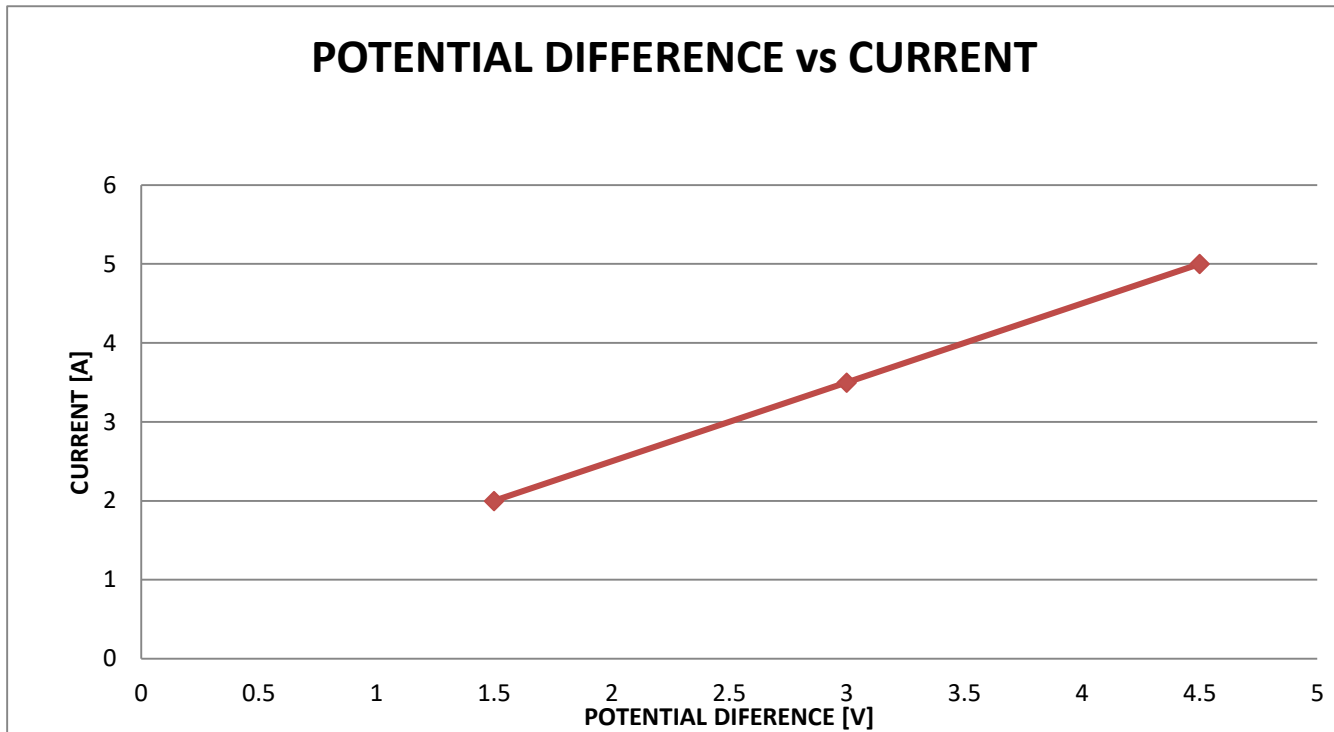

3.6  $V \propto I$

3.7

- Connect 1 battery and measure the voltmeter reading and the ammeter reading.
- $\checkmark\checkmark$
- Add another battery in series with the first and repeat the measurements
- Add a third battery in series with the first and repeat the measurements.  $\checkmark\checkmark$

OR

- Adjust the rheostat connected in series to the power source and take the readings on the ammeter and voltmeter
- Increase or decrease the resistance of the rheostat and take the second set of readings
- Increase or decrease the resistance of the rheostat and take the third set of readings.

3.8 Circuit diagram

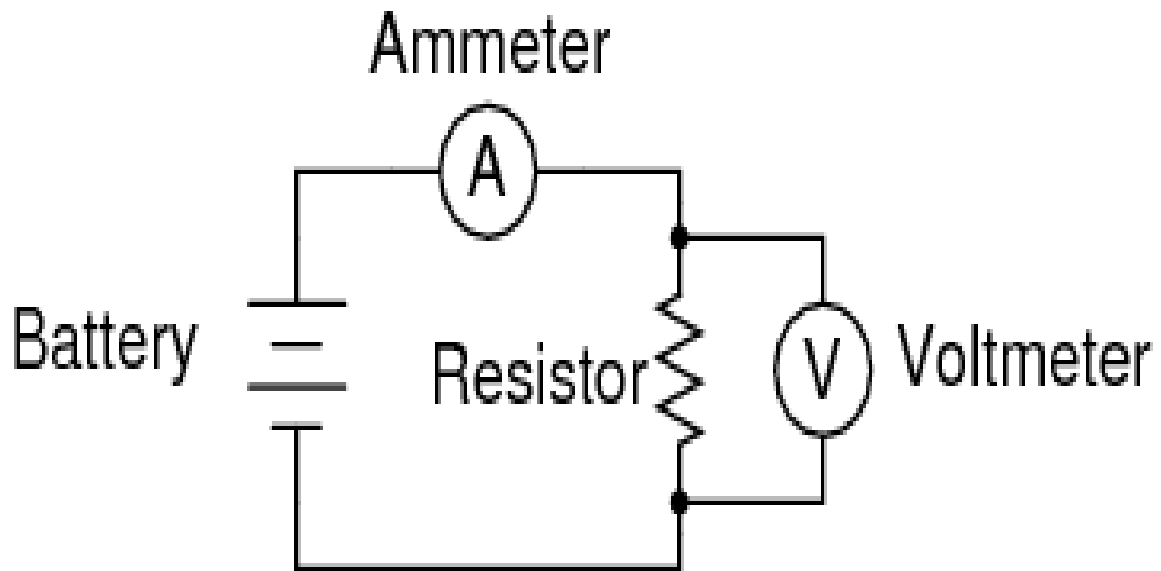

√√√√

$$3.9 \text{ m} = \frac{5-2}{4.5-1.5} = 1 \Omega \text{ } \sqrt{\sqrt{\sqrt{\sqrt{\quad}}}}$$

3.10 Resistance.√√

3.11 Due to high resistance the multi plug will shut down.√√√



UNIVERSITY of the  
WESTERN CAPE

## Appendix E:

### Interview schedule for educators

Study Title: comparing the teaching and learning of Ohm's law in grade 10 Physical Science in resourced and under-resourced schools

Interview with the Grade 10 Physical Science educators.

#### 1.1 Personal Profile

1. How many years have you taught Physical Science.
2. What qualifications do you hold?
3. What are your major subjects?
4. Up to what level have you done Physical Science?
5. What is your Home Language?

#### 1.2 Interview Questions

- Is it easy to teach Physical Science? Why?
- In what ways do you use Physical Science equipment?
- How do you rate yourself in doing practical work? Give reasons for your answer.
- What assistance do you need in conducting the experiments?
- Have you ever been trained in the use of Physical Science equipment? How effective was the training?
- What resources do you have for teaching and learning of Physical Science?
- Do you find teaching of physical science concepts effective? Explain why?
- What resources do you have to conduct Ohm's law experiment?
- In what ways does science teacher support material enhance teaching and learning?



University of the Western Cape  
Faculty of Education, Private Bag X17, Bellville, South Africa

---

APPENDIX F:

Background information sheet

Dear Sir/Madam,

My name is Nomawethu Thelma Mngonyama, a Masters student in the Science Education in the School for Science and Mathematics Education in the Faculty of Education at the University of the Western Cape. I am conducting a research on the teaching and learning of Ohm's law in Physical science in resourced and under-resourced schools.

Research Title: The teaching and learning of Ohm's law in Physical science in resourced and under-resourced schools.

The research study is guided by the following research questions:

How does teaching and learning in Ohm's Law in Physical Sciences differ in resourced and under-resourced schools?

The research participants will comprise 2 Grade 10 teachers and 100 learners. Data collection will be in the form of observations in the Grade 10 classroom, test and interviews. Participation in this study is voluntary. Participants have the right to withdraw from the research at any stage of the research process without having to give any explanations. Participants are guaranteed utmost confidentiality regarding all information collected from them. Pseudonyms or a system of coding will be used to protect their identity.

Should you wish to find out more about the research, you are welcome to contact my supervisor, Professor Hartley, whose contact details are provided below or indeed me.

Yours sincerely

Researcher: Ms. Nomawethu T. Mngonyama	Supervisor: Prof. M.S. Hartley
Contact number: 0732315293	Tel. 021-9592680
Email: nomawethumngonyama@gmail.com	Email: <a href="mailto:shartley@uwc.ac.za">shartley@uwc.ac.za</a>

Signature of the researcher: ..... Date: ...



University of the Western Cape  
Faculty of Education, Private Bag X17, Bellville, South Africa

---

## APPENDIX G: PERMISSION LETTER

THE Western Cape EDUCATION DEPARTMENT (WCED)

X Secondary School  
Stepping Stone Weg,  
Durbanville

The Research Director  
Eastern Cape Education Department  
P/B X0032  
Bisho

Dear Sir /Madam

Re: Permission to conduct research at X School

My name is Nomawethu Thelma Mngonyama, a Masters student in the Science Education in the School for Science and Mathematics Education in the Faculty of Education at the University of the Western Cape. I would like to request your permission to observe teachers 'and learners' interaction in the Grade 10 Physical Science as they are taught Ohm's law topic in one of the secondary schools in Idutywa district. I am conducting research on the teaching and learning of Ohm's law in physical science in resourced and under-resourced schools. The target group will be Grade 10 Physical science class teachers and learners in the FET band.

The research will not interfere in any way with the functioning of the school or with learning in the classroom. In addition, participation will be voluntary and so participants will be free to withdraw at any time without giving reasons should they feel uncomfortable with my research. Their participation in the study will remain anonymous. Information received as part of the study will be used for research purposes only. It will not be used in any public platform for any purposes other than to understand how the resources are used in the teaching and learning of Ohm's law in Grade10 Physical Science classroom.

Should you wish to find out more about the research, you are welcome to contact my supervisor, Professor Hartley, whose contact details are provided below or indeed me.

Yours sincerely,

Researcher: Ms.Nomawethu T. Mngonyama      Supervisor: Prof. M.S. Hartley

Contact number: 073 231 5293      Tel. 021-9592680

Email: nomawethumngonyama@gmail.com      Email: [shartley@uwc.ac.za](mailto:shartley@uwc.ac.za)

Signature of the researcher: ..... Date: ...



University of the Western Cape  
Faculty of Education, Private Bag X17, Bellville, South Africa

---

#### APPENDIX H: PERMISSION LETTER

THE PRINCIPAL X SECONDARY SCHOOL

X Secondary School,  
Stepping Stone Weg,  
7550

Durbanville

Dear Sir/Madam

Re: Permission to conduct research in your School

My name is Nomawethu Thelma Mngonyama a Masters student in the Science Education in the School for Science and Mathematics Education in the Faculty of Education at the University of the Western Cape. I am conducting research on the teaching and learning of Ohm's law in Physical Science in resourced and under-resourced schools. The target group will be Grade 10 Physical Science class teachers and learners. I would like to request your permission to observe Grade 10 teachers and learners' interaction in the teaching and learning of Ohm's law in Physical Science. I request you as the Principal of the school and the Physical Science Head of Department to participate in the interviews. I also request your permission to interview the Grade 10 teacher.

The research will not interfere in any way with the functioning of the school or with learning in the classroom. In addition, participation will be voluntary and so participants will be free to withdraw at any time without giving reasons should they feel uncomfortable with my research. Your participation and that of the learners in the study will remain anonymous. Information received as part of the study will be used for research purposes only. It will not be used in any public platform for any purposes other than to understand how the use of resources in the Physical Science topic enhances teaching and learning Physical Science in Grade 10 classroom. Should you wish to find out more about the research, you are welcome to contact my supervisor, Professor Hartley, whose contact details are provided below or indeed me.

Yours sincerely,

Researcher: Ms.Nomawethu Thelma Mngonyama

Supervisor: Prof. M.S. Hartley

Contact number: 0732315293

Tel. 021-9592680

Email: nomawethumngonyama@gmail.com

Email: shartley@uwc.ac.za

Signature of the researcher: ..... Date: ...



University of the Western Cape  
Faculty of Education, Private Bag X17, Bellville, South Africa

---

## APPENDIX I: PERMISSION LETTER

### THE GRADE 10 PHYSICAL SCIENCE TEACHER

X Secondary School,  
Stepping Stone Weg,  
7550  
Durbanville

Dear Sir/Madam

Re: Permission to conduct research in Grade 10 Physical Science classroom

My name is Nomawethu Thelma Mngonyama Masters student in the SSME Department of the Faculty of Education at the University of the Western Cape. I am conducting research on the teaching and learning of Ohm's law in Physical Science in resourced and under-resourced schools. The target group will be Grade 10 Physical Science class teachers and learners.

I would like to request your permission to observe Grade 10 teacher and learners' interaction in the Physical Science as they use resources. I also request you as the Physical Science educator to participate in the interviews.

The research will not interfere in any way with the functioning of the school or with learning in the classroom. In addition, participation will be voluntary and so participants will be free to withdraw at any time without giving reasons should they feel uncomfortable with my research. Your participation and that of the learners in the study will remain anonymous. Information received as part of the study will be used for research purposes only. It will not be used in any public platform for any purposes other than to understand how the use of resources enhances teaching in Grade 10 classroom. Should you wish to find out more about the research, you are welcome to contact my supervisor, Professor Hartley, whose contact details are provided below or indeed me.

Yours sincerely,

Researcher: Ms. Nomawethu T. Mngonyama  
Contact number: 073 231 5293  
Email: nomawethumngonyama@gmail.com

Supervisor: Prof. M.S. Hartley  
Tel. 021-9592680  
Email: [shartley@uwc.ac.za](mailto:shartley@uwc.ac.za)

Signature of the researcher: .....Date:



University of the Western Cape  
Faculty of Education, Private Bag X17, Bellville, South Africa

---

APPENDIX J: PERMISSION LETTER  
THE FET BAND GRADE 10 TEACHER

X Secondary School,  
Stepping Stone Weg,  
7550, Durbanville

Dear Sir/Madam

Re: Permission to conduct research in your Grade 10 Physical Science classroom

My name is Nomawethu Thelma Mngonyama, Masters Student in the SSME Department of the Faculty of Education at the University of the Western Cape. I am conducting research on the teaching and learning of Ohm's law in Physical Science in resourced and under-resourced schools

The target group will be Grade 10 Physical Sciences' class teacher and learners. I would like to request your permission to observe you and your learners during the Physical Science lessons in order to understand how you and your learners make use of resources in teaching and learning. I also request you to participate in the interviews and observations.

The research will not interfere in any way with the functioning of the school or with teaching and learning in your classroom. In addition, participation will be voluntary and so participants will be free to withdraw at any time without giving reasons should they feel uncomfortable with my research. Your participation and that of the learners in the study will remain anonymous. Information received as part of the study will be used for research purposes only. It will not be used in any public platform for any purposes other than to understand how the use of resources enhances teaching and learning in Grade 10 Physical Science classroom. Should you wish to find out more about the research, you are welcome to contact my supervisor, Professor Hartley, whose contact details are provided below or indeed me.

Yours sincerely,

Researcher: Ms. Nomawethu Thelma Mngonyama      Supervisor: Prof. M.S. Hartley

Contact number: 073 231 5293      Tel. 021-9592680  
Email: nomawethumngonyama@gmail.com      Email: [shartley@uwc.ac.za](mailto:shartley@uwc.ac.za)

Signature of the researcher: .....Date:



University of the Western Cape  
Faculty of Education, Private Bag X17, Bellville, South Africa

---

#### APPENDIX K: PERMISSION LETTER

THE PARENTS  
X Secondary School,  
Stepping Stone Weg,  
7550  
Durbanville

Dear Sir/Madam

Re: Permission for your child's participation in a research in

My name is Nomawethu Thelma Mngonyama Masters student in the SSME Department of the Faculty of Education at the University of the Western Cape. I am conducting research on the teaching and learning of Physical in Ohm's law in Physical Science in resourced and under-resourced schools.

The target group will be your Grade 10 Physical Sciences' learner.

I would like to request your permission to include your child participation in Physical Science class and observe how he/she interacts with his/her teacher and peers. I would also like to observe her/his written activities.

The research will not disrupt the class schedules or teaching and learning in the classroom. In addition, participation will be voluntary, so participants will be free to withdraw at any time without giving reasons should they feel uncomfortable with my research. The identity of the learners in the study will remain anonymous. Information received as part of the study will be used for research purposes only. It will not be used in any public platform for any purposes other than to understand how the use of resources enhances teaching and learning.

Should you wish to find out more about the research, you are welcome to contact my supervisor, Professor Hartley, whose contact details are provided below or indeed me.

Yours sincerely,

Researcher: Ms. Nomawethu Thelma Mngonyama      Supervisor: Prof. M.S. Hartley  
Contact number: 073 231 5293      Tel. 021-9592680  
Email: nomawethumngonyama@gmail.com      Email: [shartley@uwc.ac.za](mailto:shartley@uwc.ac.za)

Signature of the researcher: .....Date:



University of the Western Cape  
Faculty of Education, Private Bag X17, Bellville, South Africa

---

Appendix L:

Participants 'informed Consent form:

I agree to be part of the study and I am aware that my participation in this study is voluntary. If, for any reason, I wish to stop being part of the study, I may do so without having to give an explanation. I understand the intent and purpose of this study.

I am aware the data will be used for a Master's thesis and a research paper. I have the right to review, comment on, and/or withdraw information prior to the paper's submission. The data gathered in this study are confidential and anonymous with respect to my personal identity, unless I specify or indicate otherwise. In the case of classroom observations and interviews, I have been promised that my personal identity and that of the school will be protected, and that my duties will not be disrupted by the researcher.

I have read and understood the above information. I give my consent to participate in the study.

\_\_\_\_\_

Participant's signature

\_\_\_\_\_

Date

\_\_\_\_\_

Researcher's signature

\_\_\_\_\_

Date

